

# CLARKE®



## DUAL VOLTAGE DIESEL/PARAFFIN HEATERS MODEL NO: XR60DV, XR80DV, XR110DV, XR160DV, & XR210DV

PART NO: 6931015, 6931019, 6931023, 6931027 & 6931032

## OPERATION & MAINTENANCE INSTRUCTIONS

UK  
CA | CE



ORIGINAL INSTRUCTIONS

GC08/23 -Rev 1

## INTRODUCTION

Thank you for purchasing this CLARKE product. Before attempting to use this product, please read this manual thoroughly and follow the instructions carefully.

## SPECIFICATIONS

Model	XR60DV	XR80DV	XR110DV	XR160DV	XR210DV
Part No	6931015	6931019	6931023	6931027	6931032
Burn Rate: (Btu/hr)	50,000	70,000	100,000	160,000	210,000
Fuel consumption	1.6 L/hr	1.9 L/hr	2.8 L/hr	3.91 L/hr	4.16 L/hr
Approx Running Time	9.4 hr	11.9 hr	11.4 hr	13.5 hr	12.7 hr
Electrical input	110v/230V ~ 50Hz				
Power	175 W	185 W	195 W	310 W	350 W
Max.Outlet Temp	1300°F (704°C)				
Fuel Tank Capacity	15 L	22.7 L	32 L	53 L	53 L
Ignition system	Electric Ignition				
Primary Safety Control	Flame failure device				
Weight (kg)	15.2	15.5	18.3	24.6	24.6
Dims (D x W x H) mm	830 x 410 x 628	830 x 410 x 648	905 x 413 x 700	1045 x 528 x 692	1045 x 528 x 692
Minimum Fuel Level	5L	6L	6L	10L	10L

## ENVIRONMENTAL RECYCLING POLICY



Through purchase of this product, the customer is taking on the obligation to deal with the WEEE in accordance with the WEEE regulations in relation to the treatment, recycling & recovery and environmentally sound disposal of the WEEE.

In effect, this means that this product must not be disposed of with general household waste. It must be disposed of according to the laws governing Waste Electrical and Electronic Equipment (WEEE) at a recognised disposal facility.

---

## GUARANTEE

---

This product is guaranteed against faulty manufacture for a period of 12 months from the date of purchase. Please keep your receipt which will be required as proof of purchase.

This guarantee is invalid if the product is found to have been abused or tampered with in any way, or not used for the purpose for which it was intended.

Faulty goods should be returned to their place of purchase, no product can be returned to us without prior permission.

This guarantee does not effect your statutory rights.

---

## FUNCTION AND OPERATING PARAMETERS

---

This is a multi-fuel (Diesel or Paraffin), forced air heater. It's intended use is for drying and the warming of commercial/industrial buildings where adequate ventilation is provided.

This is a forced air unit, where a fan pushes the air through the heater body. Proper combustion depends upon this air flow; therefore, the heater must not be, modified or operated with parts removed or missing. Likewise, safety systems must not be circumvented or modified in order to operate the heater.

- It must be operated as prescribed in the operating manual.
- Is not intended to be used for domestic use or for the heating of habitable areas.
- Is not intended to be used to reach and maintain a certain level of human thermal comfort within an enclosed space in which the heater is situated.
- Is not intended to be used in enclosed areas with restricted ventilation.
- Is not for use in areas with high levels of fluctuating drafts.
- **The heater must be placed on a flat, level, non combustible surface during operation.**
- Is not intended for warming animals or live stock.

---

## SAFETY WARNINGS

---

**Your safety is important to you and to others, so please read these instructions before you operate this heater.**

1. Failure to comply with the precautions and instructions provided with this heater can result in death, serious bodily injury and property loss or damage from the hazards of fire, explosion, burns, asphyxiation, carbon monoxide poisoning, and/or electric shock.
2. Only persons who understand and follow the instructions should use or service this heater.
3. When used, the heater should rest on a suitable insulating material extending beyond the heater in all directions
4. This heater is not for home or recreational vehicle use.
5. **DO NOT** use petrol or volatile fuels.
6. Disconnect the heater from the power supply before adding fuel.
7. **ALWAYS** re-fuel outdoors away from any open flame or other sources of ignition.
8. **DO NOT** use an external fuel source.
9. **DO NOT** use the heater where flammable liquids or vapours may be present.
10. **DO NOT** start the heater when the combustion chamber is hot.
11. Plug the electrical cable into a properly earthed power supply.
12. **DO NOT** leave the heater unattended when in use.
13. **DO NOT** start or use the heater if there is unburnt fuel in the combustion chamber.
14. The heater must be placed on flat, level, non combustible surface during operation.

---

## SAFETY SYMBOLS

---

The following symbols appear on the unit.



Hot Surface, do not touch



High Voltage

---

## SAFETY PRECAUTIONS

---

1. Check the heater thoroughly for damage. Never operate a damaged heater.
2. This heater is for indoor use only. Make sure that the heater is not directly exposed to rain or water spray.
3. Use in well ventilated spaces and provide at least 2 sq. ft. (0.19 sq.m.) of air opening near the floor and 2 sq. ft. (0.19 sq. m.) near the ceiling directly to outdoors. Increase air openings for each additional heater.
4. **ALWAYS** keep combustibles, like paper and wood at least 8 ft. (2.4 m) from the front of the heater and 3 ft. (1 m) from the top, sides and rear.
5. Locate the heater 3 m from canvas or plastic coverings and secure them to prevent movement.



CAUTION: DUE TO THE HIGH SURFACE AND EXHAUST TEMPERATURES, ADULTS AND CHILDREN MUST KEEP CLEAR OF THE UNIT TO AVOID BURNS OR CLOTHING IGNITION.

---

6. **NEVER** use in living spaces and/or where children may be present.
7. **DO NOT** use with ductwork. **DO NOT** restrict air inlet or exit.
8. **DO NOT** move or attempt to service the heater while hot or in operation.
9. Use only in accordance with local regulations and relevant building codes.
10. The heater is not to be used by children or persons with reduced physical, sensory or mental capabilities, or lack of experience and knowledge.
11. If the supply cable is damaged it must be replaced by the manufacturer, its service agent, or similarly qualified persons in order to avoid a hazard.
12. Locate the heater at a safe distance from combustible materials.
13. When used, the heater should stand on suitable insulating material extending beyond the heater in all directions.
14. Only operate on a flat level and stable surface.

---

# FRESH AIR PRECAUTIONS

---

## VENTILATION

Even though this heater operates very close to 100 percent combustion efficiency, it still produces small amounts of carbon monoxide.

Carbon monoxide (CO) is toxic.

CO can build up in a confined spaces and failure to provide adequate ventilation can be fatal.

The early symptoms of asphyxiation caused by inadequate ventilation are:

- headache
- nausea
- dizziness
- dry mouth or sore throat

The following groups of people are more likely to be effected by Carbon Monoxide.

1. Pregnant women,
2. Persons with a heart or lung condition, anaemia
3. People under the influence of alcohol,
4. Those living/working at high altitude

## WHAT TO DO IF YOU SUSPECT CO POISONING

- Get fresh air immediately. Open doors and windows, switch off the heater and leave the area.
- See your doctor immediately or go to hospital - let them know that you suspect CO poisoning. They can do a blood or breath test to check.

Do not use the heater until it has been serviced.

Be sure to follow all warnings in this manual.

## BYSTANDERS

When the heater is to be operated in the presence of other people the user is responsible for informing those present of the safety precautions and of the hazards involved.

## WE RECOMMEND THE USE OF A CARBON MONOXIDE DETECTOR

## ELECTRICAL CONNECTIONS



**WARNING: READ THESE ELECTRICAL SAFETY INSTRUCTIONS THOROUGHLY BEFORE CONNECTING THE PRODUCT TO THE MAINS SUPPLY.**

Connect the mains lead to a standard, 230 Volt (50Hz) electrical supply through an approved BS1363/A plug fitted with a BS1362 13 amp fuse.

The heater may also be connected to a 110V supply through a suitably approved plug. The control module of the heater will determine if the unit is connected to a 230 or 110V power supply.

If the plug has to be changed because of damage, it must be removed and a replacement fitted, following the wiring instructions shown below. The old plug must be discarded safely, as insertion into a power socket could cause an electrical hazard.



**WARNING: WIRES IN THE MAINS LEAD ARE COLOURED IN ACCORDANCE WITH THE FOLLOWING CODE: GREEN/YELLOW = EARTH, BLUE = NEUTRAL, BROWN = LIVE.**

- The BLUE wire must be connected to the terminal which is marked N or coloured black.
- The BROWN wire must be connected to the terminal which is marked L or coloured red.
- The YELLOW AND GREEN wire must be connected to the terminal which is marked E or  $\perp$  or coloured green.

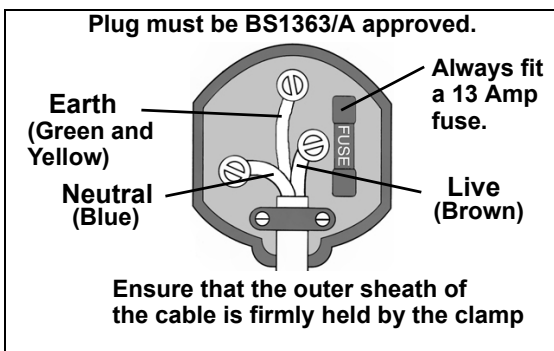

**We strongly recommend that this machine is connected to the mains supply through a Residual Current Device (RCD)**

**If you are not sure, consult a qualified electrician. DO NOT try to do any repairs.**

## UNPACKING AND ASSEMBLY

Remove the heater from carton and discard all protective material which may have been applied to the heater for shipment. Recycle packaging materials responsibly.

1. Pass the axle through the wheel frame as shown
2. Add a flat washer and secure everything in place by inserting a split pin into the small hole at the end of the axle.

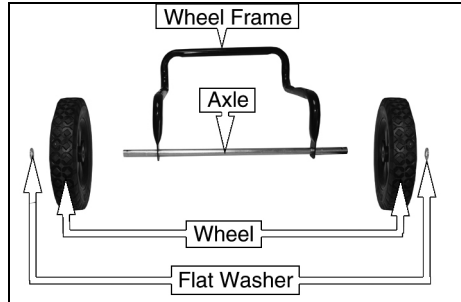

3. Fit the handle into position and secure using four bolts and nuts provided (2 each side).



4. Fit the front rail into position and secure using four bolts and nuts provided (2 each side).

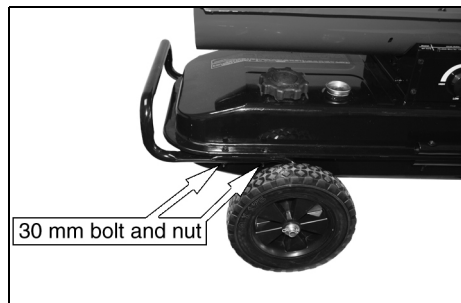



---

# PREPARATION

---

## SUITABLE FUELS

Diesel or paraffin are the only fuels that should be used in this heater.

## FILLING THE FUEL TANK

**IMPORTANT:** Before filling the fuel tank the first time or after extended storage periods, drain the fuel tank of any moisture or condensation.

1. Follow all of the "Safety Precautions".
2. Remove the fuel cap.

**NOTE:** If you lose the fuel cap a replacement must be obtained before use, this is available from your local Clarke dealer.

3. Fill the fuel tank with clean diesel or paraffin.

- In cold weather, condensation may develop in the tank if the tank is empty and it is recommended that a tablespoon of de-icer be added for each gallon of fuel in the tank.
- When filling the heater, make sure that the heater is level and do not overfill. Use a funnel or can with a long fill spout.
- Fill with a minimum of 5 litres of fuel for the XR60DV, 6 litres for the XR80DV & XR110DV, or 10 litres the XR160DV and XR210DV.

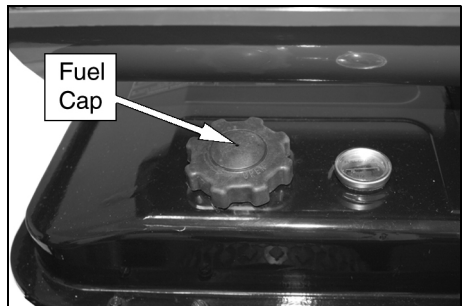

## POSITIONING THE UNIT

- Locate heater at a safe distance from combustible materials.
- When used, the heater should rest on suitable insulating material extending beyond the heater in all directions.
- Only operate on a flat level and stable surface.

# OPERATION

## STARTING UP



**WARNING: DO NOT START HEATER WHEN EXCESS FUEL HAS ACCUMULATED IN THE COMBUSTION CHAMBER.**

1. Make sure power switch is in the OFF position.
2. Turn thermostat to lowest setting.
3. Plug the heater into the power supply (either 230V or 110V).

**NOTE:** The voltage setting needs to match the available power supply. The onboard circuit will identify the input.

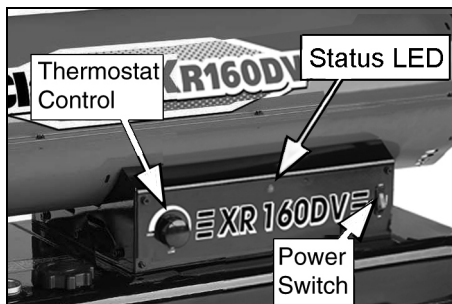

4. Set the power switch to the ON position.

LED status	UNIT OPERATION
Steady light	Unit is performing a self-test.
Off	Operation OK
2 Flashes	No flames detected.
3 Flashes	High limit switch failure. Unit has overheated.
4 Flashes	Flame sensor failure.

See Troubleshooting on page 14 if the above error conditions occur.

- The switch will illuminate in the ON position.
5. Adjust the thermostat to the desired heat setting.
    - The heater will cycle on/off as heat is required.

## SHUTTING DOWN

1. Set the power switch to the OFF position.
2. For extended shutdown, unplug the heater from the power supply.
3. Before storage, Clean the heater as described in the Maintenance section.

---

# MAINTENANCE, STORAGE AND SERVICING

---



**WARNING: TO PREVENT PERSONAL INJURY, UNPLUG THE HEATER FROM THE MAINS SUPPLY BEFORE SERVICING.**

---

## GENERAL

1. Make a general visual inspection of the heater for loose or damaged parts.
  - Damaged parts should be repaired or replaced before using the heater again.
2. Check heater operation to be sure it is operating normally as follows:
  - The flame is contained within the heater.
  - The flame is essentially yellow without smoke or soot.
  - There is no disagreeable odor, eye burning or other discomfort.

## 6-MONTHLY

1. Clean the heater twice a season (more often under dusty conditions). Remove accumulated dust from the transformer, burner, motor and fan blades with compressed air.
2. Clean out the fuel tank (every 500 Hours) (during frequently used periods, clean twice a month). Drain and flush the fuel tank with clean fuel.

The XR160DV and XR210DV have a rubber drain plug on the bottom of the tank. Place a suitable container beneath the drain plug and pull out the plug, replace the plug before filling the tank again.

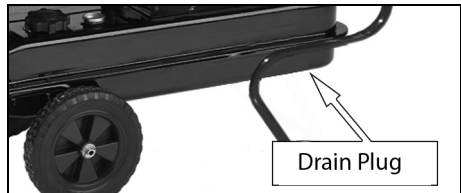

## ANNUALLY

Clean the air output filter. Remove the air output filter and tap the contaminated side gently on a solid object to remove contaminants.

Clean the air intake filter when required (approx 500 hours). Remove and wash in mild detergent. Dry thoroughly and refit.

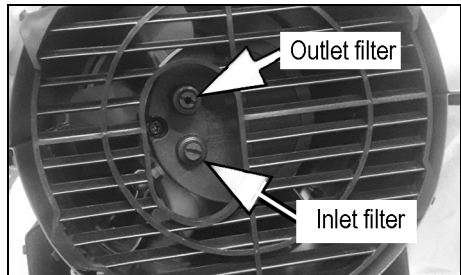

## FILTERS

Dirty air filters will cause an imbalance in the air-fuel mixture. The best indication that this condition exists is an increase in odour or difficulty getting your heater to ignite. This heater should never be operated without the filters in place. If required, clean the filters as follows.

### ACCESSING THE FILTERS

1. Make sure that the plug is removed from the power supply before carrying out any maintenance.
2. Remove the six screws shown and remove the top cover of the heater.

**NOTE:** There may be eight screws on the larger models.

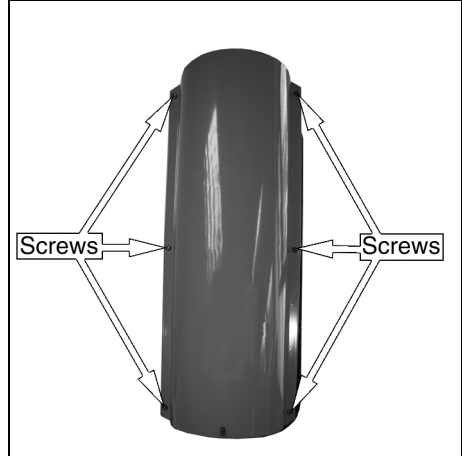

3. Lift out the rear guard.

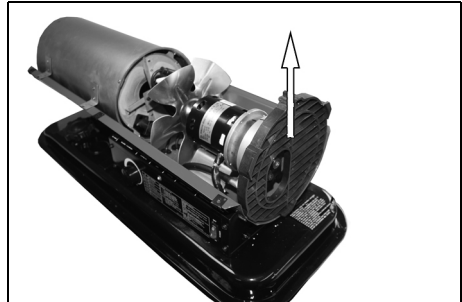

4. Remove the 3 screws securing the filter cover.
5. Pull the filter cover away from the motor.

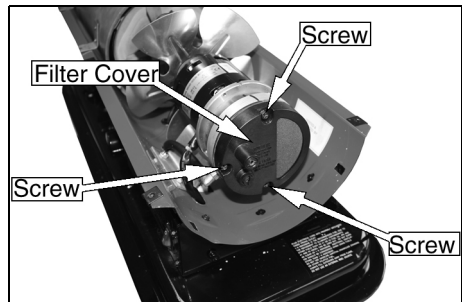

## AIR INTAKE FILTER CLEANING

6. To clean the air intake filter.
  - Remove and wash the filter element with a mild detergent.
  - Dry thoroughly and refit.
  - DO NOT oil the filter element. If your heater is used where there is considerable dust or dirt.
  - Clean as often as necessary (at least approximately every 500 hrs.).

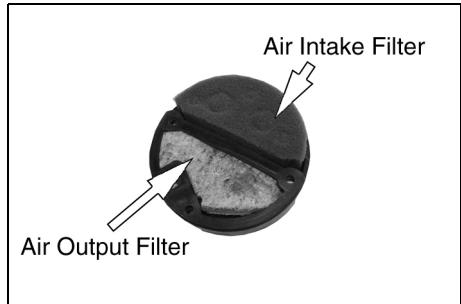

**NOTE:** If the filter is damaged or extremely dirty, a replacement filter of the same type must be fitted, this is available from your local CLARKE service department.

## AIR OUTPUT FILTER CLEANING

7. To clean the air output filter (Annually or as required) remove the air output filter and tap the contaminated side gently on a solid object to remove contaminates.

**NOTE:** Compressed air or liquids should not be used to clean this filter.

**NOTE:** If the filter appears damaged or extremely dirty replace it with a new filter of the same type, obtained from your local CLARKE service department.

8. Reinstall the clean filter into the filter housing.
9. Replace the filter cover and secure using the screws removed in step 4.

**NOTE:** When replacing the filter cover, make sure that the gasket is firmly in place and the screws in the filter cover are tight to prevent air leaks. if the gasket is damaged a replacement must be obtained and fitted this is available from your local CLARKE service department.

10. Refit the rear guard and replace the top cover.
11. Make sure all screws are replaced before use.

## STORAGE

1. Drain any residual fuel / condensate from the fuel tank (see page 10).
2. Store the heater in a dry location free from fumes or dust.

## TROUBLESHOOTING

LED	OPERATION	TROUBLE SHOOTING
LED gives 2 Flashes	No flame detected	Heater fails to start. 1. Check fuel level 2. Check the mains plug is correctly fitted and that the fuse inside it has not blown. 3. Return to Clarke service department for repair.
LED gives 3 Flashes	High limit switch failure. (unit has overheated)	Make sure heater is cooled down, 1. Make sure that the power switch is set to the OFF position. 2. Wait 5 minutes 3. Start heater by setting the power switch to the ON position.
LED gives 4 Flashes	Flame sensor failure	Return to CLARKE service department for repair.

# WIRING DIAGRAM

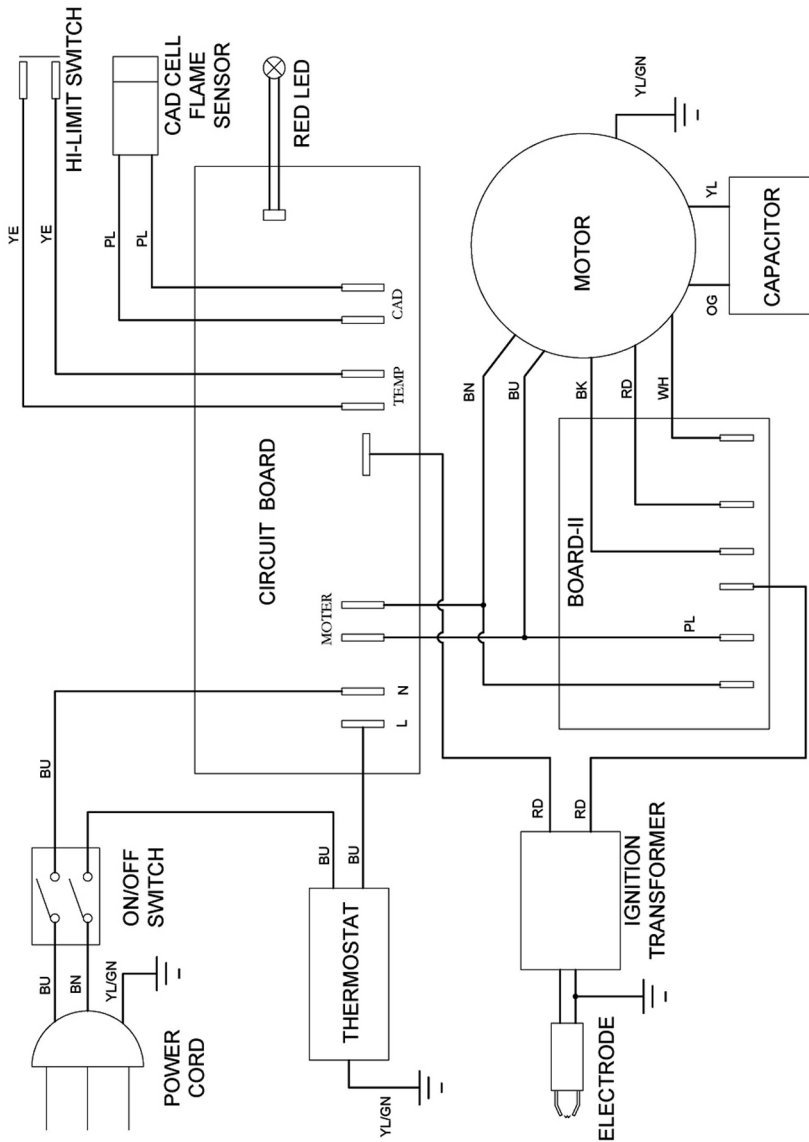

# COMPONENT PARTS

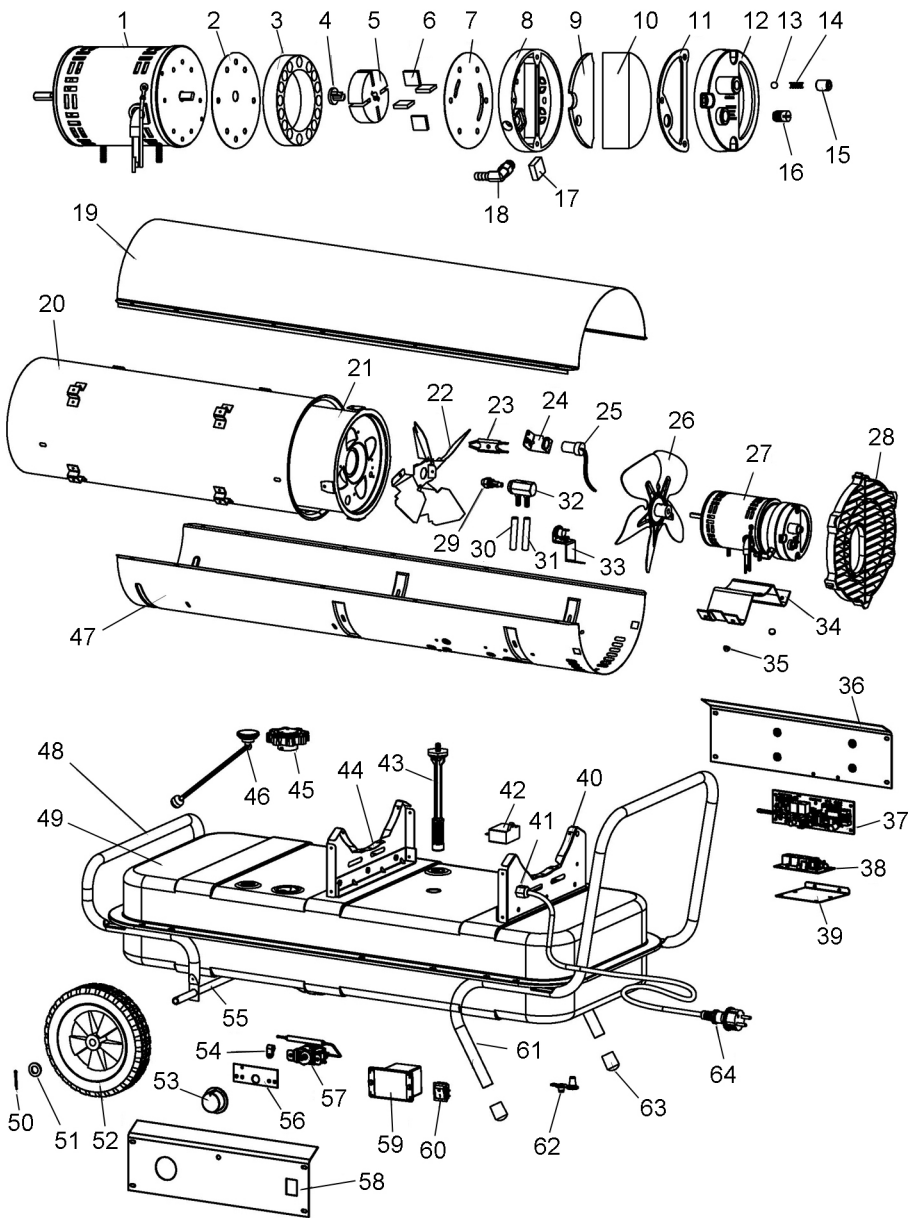



# COMPONENT PARTS

No.	PART	XR60DV	XR80DV	XR110DV	XR160DV	XR210DV
1	Assembly, motor	1A	1A	1A	1B	1B
2	SS sheet A	2A	2A	2A	2B	2B
3	Air pump cylinder	3	3	3	3	3
4	Air pump insert	4	4	4	4	4
5	Rotor, air pump	5	5	5	5	5
6	Vane, air pump	6	6	6	6	6
7	SS sheet B	7	7	7	7	7
8	Outlet housing, air filter	8	8	8	8	8
9	Assembly, outlet filter	9	9	9	9	9
10	Inlet filter	10	10	10	10	10
11	Gasket, outlet filter	11	11	11	11	11
12	Inlet housing, air filter	12	12	12	12	12
13	Ball, pressure adjustment	13	13	13	13	13
14	Spring, pressure adjusting	14	14	14	14	14
15	Pump adjusting screw	15	15	15	15	15
16	Nylon pipe plug	16	16	16	16	16
17	Outlet filter	17	17	17	17	17
18	Hose barb adapter	18	18	18	18	18
19	Top shell	19A	19A	19B	19C	19C
20	Assembly, outer cylinder	20A	20B	20C	20D	20D
21	Assembly, middle cylinder	—	—	21A	21B	21B
22	Mounting plate nozzle	22A	22A	22B	22C	22C
23	Assembly, electrode	23	23	23	23	23
24	Support, cad cell	24	24	24	24	24
25	Assembly, cad cell flame sensor	25	25	25	25	25
26	Assembly, fan	26A	26B	26C	26C	26D
27	Assembly, power Pac	27A	27B	27C	27D	27E
28	grille	28A	28A	28B	28B	28B
29	nozzle	29A	29B	29C	29D	29E
30	Air tube	30A	30A	30B	30B	30B
31	Fuel tube	31A	31A	31B	31C	31C
32	Nozzle adapter	32A	32A	32B	32B	32B
33	Assembly, hi-limit switch	33A	33A	33B	33B	33B
34	Motor mounting brkt	34A	34A	34B	34C	34C
35	Anti-vibrator, motor	35	35	35	—	—
36	Right panel	36A	36A	36B	36C	36C
37	Assembly, flame control	37	37	37	37	37
38	Circuit board II	38	38	38	38	38
39	Circuit board support	39	39	39	39	39

# COMPONENT PARTS

No.	PART	XR60DV	XR80DV	XR110DV	XR160DV	XR210DV
40	Back panel	40A	40A	40B	40C	40C
41	Bushing strain relief	41	41	41	41	41
42	Capacitor	42A	42A	42A	42B	42B
43	Assembly, fuel filter	43A	43B	43C	43D	43D
44	Front panel	44A	44A	44B	44C	44C
45	Assembly, fuel cap	45	45	45	45	45
46	Assembly, fuel gauge	—	46A	46B	46B	46B
47	Bottom shell	47A	47A	47B	47C	47C
48	Haddle, front	48A	48A	48A	48B	48B
49	Assembly, fuel tank	49A	49B	49C	49D	49D
50	Cotter pin	50	50	50	50	50
51	Washer	51	51	51	51	51
52	Wheel	52	52	52	52	52
53	Knob	53	53	53	53	53
54	Loop clamp	54	54	54	54	54
55	Axle	55A	55A	55A	55B	55B
56	Mounting plate , Thermostat	56	56	56	56	56
57	Assembly , Thermostat	57	57	57	57	57
58	Left panel	58A	58A	58B	58C	58C
59	Assembly, igniter transformer	59	59	59	59	59
60	ON/OFF switch	60	60	60	60	60
61	Handle, Back	61A	61A	61B	61C	61C
62	Draining plug	—	—	—	62	62
63	Tube socks	63	63	63	63	63
64	Power cord	64	64	64	64	64

# DECLARATIONS OF CONFORMITY



**Clarke**  
INTERNATIONAL

Hermold Street, Epping, Essex CM16 4LG

**DECLARATION OF CONFORMITY**

This is an important document and should be retained.

We hereby declare that this product(s) complies with the following statutory requirement(s):

*Electromagnetic Compatibility Regulations 2016*  
*Electrical Equipment (Safety) Regulations 2016*  
*The Restriction of the Use of Certain Hazardous Substances in Electrical and Electronic Equipment Regulations 2012*

The following standards have been applied to the product(s):

EN 55014-1:2017+A1:2020, EN 55014-2:2015, EN 61000-3-2:2014, EN 61000-3-3:2013,  
EN 60335-2-102:2016, EN 60335-1:2012+A11:2014+A13:2017+A1:2019+A2:2019+A14:2019,  
EN 62233:2008, IEC 62321-3-1:2013, IEC 62321-4:2013, IEC 62321-5:2013, IEC 62321-6:2015,  
IEC 62321-7-1:2015, IEC 62321-7-2:2017, IEC 62321-8:2017.

The technical documentation required to demonstrate that the product(s) meet(s) the requirement(s) of the aforementioned legislation has been compiled and is available for inspection by the relevant enforcement authorities.

The UKCA mark was first applied in: 2023

Page 1 of 1

**Product Description:** Dual Voltage Paraffin / Diesel Fired Space Heaters

**Model number(s):** XR60DV, XR80DV, XR110DV, XR160DV, XR210DV

**Serial / batch Number:** N/A

**Date of Issue:** 18/05/2023

**Signed:** 

J.A. Clarke  
Director

Page 1 of 1



**Clarke**  
INTERNATIONAL

Fitzwilliam Hall, Fitzwilliam Place, Dublin 2

**DECLARATION OF CONFORMITY**

This is an important document and should be retained.

We hereby declare that this product(s) complies with the following directive(s):

*2014/30/EU Electromagnetic Compatibility Directive*  
*2014/35/EU Low Voltage Directive*  
*2011/65/EU Restriction of the Use of Certain Hazardous Substances in Electrical and Electronic Equipment Directive*

The following standards have been applied to the product(s):

EN 55014-1:2017+A1:2020, EN 55014-2:2015, EN 61000-3-2:2014, EN 61000-3-3:2013,  
EN 60335-2-102:2016, EN 60335-1:2012+A11:2014+A13:2017+A1:2019+A2:2019+A14:2019,  
EN 62233:2008, IEC 62321-3-1:2013, IEC 62321-4:2013, IEC 62321-5:2013, IEC 62321-6:2015,  
IEC 62321-7-1:2015, IEC 62321-7-2:2017, IEC 62321-8:2017.

The technical documentation required to demonstrate that the product(s) meet(s) the requirement(s) of the aforementioned directive(s) has been compiled and is available for inspection by the relevant enforcement authorities.

The CE mark was first applied in: 2023

Page 1 of 1

**Product Description:** Dual Voltage Paraffin / Diesel Fired Space Heaters

**Model number(s):** XR60DV, XR80DV, XR110DV, XR160DV, XR210DV

**Serial / batch Number:** N/A

**Date of Issue:** 18/05/2023

**Signed:** 

J.A. Clarke  
Director

Page 1 of 1

# A SELECTION FROM THE VAST RANGE OF

# Clarke®

## QUALITY PRODUCTS



### **AIR COMPRESSORS**

From DIY to industrial, Plus air tools, spray guns and accessories.

### **GENERATORS**

Prime duty or emergency standby for business, home and leisure.

### **POWER WASHERS**

Hot and cold, electric and engine driven - we have what you need

### **WELDERS**

Mig, Arc, Tig and Spot. From DIY to auto/industrial.

### **METALWORKING**

Drills, grinders and saws for DIY and professional use.

### **WOODWORKING**

Saws, sanders, lathes, mortisers and dust extraction.

### **HYDRAULICS**

Cranes, body repair kits, transmission jacks for all types of workshop use.

### **WATER PUMPS**

Submersible, electric and engine driven for DIY, agriculture and industry.

### **POWER TOOLS**

Angle grinders, cordless drill sets, saws and sanders.

### **STARTERS/CHARGERS**

All sizes for car and commercial use.

## **PARTS & SERVICE: 0208 988 7400**

### **Parts Enquiries**

[Parts@clarkeinternational.com](mailto:Parts@clarkeinternational.com)

### **Servicing & Technical Enquiries**

[Service@clarkeinternational.com](mailto:Service@clarkeinternational.com)

SALES: UK 01992 565333 or Export 00 44 (0)1992 565335

**Clarke** INTERNATIONAL Hemnall Street, Epping, Essex CM16 4LG  
[www.clarkeinternational.com](http://www.clarkeinternational.com)