

Clarke®

weld



PRESSURE REGULATOR

MODEL NO: IR1A, IR2A, IR1C & IR2C

PART NO: 8134060, 8134070, 8134090 & 8134100

OPERATING & MAINTENANCE INSTRUCTIONS

ORIGINAL INSTRUCTIONS

GC0821 REV 1

INTRODUCTION

Thank you for purchasing this CLARKE Industrial Pressure Regulator.

Before attempting to use this product, please read this manual thoroughly and follow the instructions carefully. In doing so you will ensure the safety of yourself and that of others around you, and you can look forward to your purchase giving you long and satisfactory service.

Your regulator has been designed to give long and trouble free service. If, however, having followed the instructions in this booklet carefully, you encounter problems, take the unit to your local CLARKE dealer.

SPECIFICATIONS

Colour	Black
ID-Code	N
K-Class	1
Inlet Pressure (P1) bar	300
Outlet Pressure(P2) bar	4
Delivery flow (Q1) m ³ /h	2

GUARANTEE

This product is guaranteed against faulty manufacture for a period of 12 months from the date of purchase. Please keep your receipt which will be required as proof of purchase.

This guarantee is invalid if the product is found to have been abused or tampered with in any way, or not used for the purpose for which it was intended.

Faulty goods should be returned to their place of purchase, no product can be returned to us without prior permission.

This guarantee does not effect your statutory rights.

SAFETY PRECAUTIONS



CAUTION: FAILURE TO FOLLOW THESE PRECAUTIONS COULD RESULT IN PERSONAL INJURY, AND/OR DAMAGE TO PROPERTY.

- Incorrect use of the pressure reducer can cause serious damage.
 - Users must be trained technicians or else, under full supervision.
 - ALWAYS check to ensure the reducer is the correct model for the type of gas being used.
 - The pressure reducer must be treated as a precision instrument.
 - Protect it from accidental knocks, dust, oil and other sources of dirt.
 - DO NOT use the pressure reducer if it is not in perfect working order.
 - When you draw gas, the cylinder must be placed upright and protected from falling.
 - Ensure the inlet connection gasket (2) is always in place and in good condition (CO2 ONLY).
-

FUNCTION

The function of the pressure regulator is to reduce and stabilise the pressure of a gas; the reducer changes the pressure at which the gas is kept in the cylinder into the pressure needed for use.

The pressure reducer has been designed to be used exclusively with the type of gas, and at the pressure, which is shown by the markings (see 'Markings' - page 6) and the metal I.D. tag.

IMPORTANT: To use the pressure reducer with types of gasses and pressures other than Argon/CO2 could be dangerous.

ASSEMBLY

Refer to parts diagram - page 7.

CONNECTION OF THE PRESSURE REDUCER

1. Check to ensure the pressure reducer is correct both for the type of gas and the pressure in the cylinder to be used.
2. Turn the pressure adjuster (6) fully anticlockwise, to ensure the pressure reducer valve is closed.
3. Before screwing on the pressure reducer, briefly open the cylinder valve (1) then close it, in order to remove any impurity, dust etc. from the outlet.
4. Replace the gasket (2) if damaged or lost (CO2 ONLY).

NOTE: During this operation DO NOT place your hands over the cylinder outlet.

5. Screw the inlet connection (3) tightly to the cylinder valve, using a suitable spanner.

HOSE CONNECTION

1. Attach the hose to the hose connection of the outlet connection (8) and tighten with suitable clamps (not provided).

INSTRUCTIONS FOR USE

OPENING THE PRESSURE VALVE

1. Check to ensure the reducer is completely closed (turn the pressure adjusting knob (6) fully anticlockwise).
2. Slowly open the cylinder valve (1). The high pressure gauge (4) will indicate the cylinder pressure.

WARNING: OPENING THE CYLINDER VALVE TOO QUICKLY MAY CAUSE THE GAUGE TO MALFUNCTION.

3. Turn the pressure adjusting knob (6) very slowly clockwise. The low pressure gauge (5), if fitted, will indicate the outlet pressure.

HOW TO REGULATE THE PRESSURE

1. To increase pressure; slowly turn the reducer pressure adjuster (6) clockwise until the reading on the gauge (if fitted) is at the pressure recommended by the tools' manufacturer.
2. To decrease pressure; slowly turn the reducer pressure adjuster (6) anticlockwise.

NOTES

- As the pressure drops, compensate by screwing the adjuster knob (6) clockwise.
- Outlet pressure must not be regulated higher than the pressure you need to use.
- Outlet pressure must not be regulated higher than the red mark on the low pressure gauge (when fitted).

SHUTTING DOWN

1. Close the cylinder valve (1)
2. Release the gas, by operating the tool, until the reducer gauge indicates "zero", or no more gas can be heard exhausting.
3. Turn the pressure adjuster (6) anticlockwise until it is completely closed.

THE RELIEF VALVE

For safety reasons, the pressure reducer is equipped with a safety pressure valve.

In case of malfunctioning, this valve allows gas, at excessive pressure, to escape.

WARNING: DO NOT ATTEMPT TO RE-CALIBRATE THE RELIEF VALVE.

STORAGE

The pressure reducer must be treated as a precision instrument. When it is not to be used for long periods, store it in its wrapping or in its box, to prevent contact with dust, oil and other sources of dirt.

MAINTENANCE

Do not carry out maintenance or repairs other than the following.

- Use only original CLARKE spare parts and accessories. (see your dealer).
- DO NOT dismantle the gauge assembly. Return to your CLARKE dealer for servicing.
- DO NOT clean the gauge glass with solvents - petrol etc.

MALFUNCTIONS

DO NOT use the pressure reducer if the following conditions prevail:

- The pressure reducer or any of its parts (gauge, inlet connection, outlet connection) are damaged or dirty, oily etc.
- There are any leaky connections.
- The relief valve adjustment has been modified or the valve leaks.

If the gauge malfunctions during use, (e.g. leaks in the gauges or in the relief valves) discontinue use immediately and close the cylinder valve.

Return the regulator to your dealer to be checked and repaired.

CHECKING FOR LEAKS

This check must be carried out only in the open air: use either soapy water or a gas leak detector. **DO NOT use a naked flame.**

- Spray detector or apply soapy water to the area to be checked.
- The forming of bubbles or foam is a sign of a leak.

PRODUCT MARKINGS

1. Lot (number/year)
2. Type of gas (code)
3. Pressure regulator class
4. Maximum inlet pressure

PARTS LIST & DIAGRAM

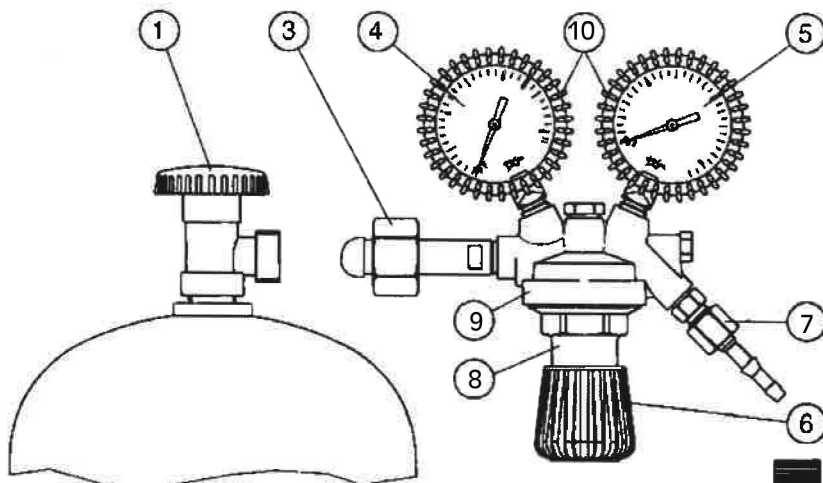

Markings

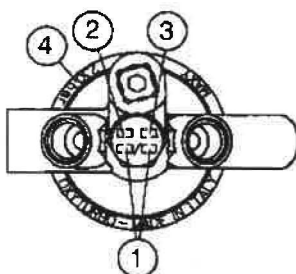

No	Description
1	Cylinder Valve
2	Inlet connection gasket
3	Inlet connection
4	High pressure gauge
5	Low pressure gauge

No	Description
6	Pressure adjusting knob
7	Outlet connection
8	Cover
9	Body
10	Gauge cover

ACCESSORIES

A wide range of welding accessories is available.

Contact your CLARKE dealer for further information or CLARKE International Service Department.

A SELECTION FROM THE VAST RANGE OF

Clarke®

QUALITY PRODUCTS



AIR COMPRESSORS

From DIY to industrial, Plus air tools, spray guns and accessories.

GENERATORS

Prime duty or emergency standby for business, home and leisure.

POWER WASHERS

Hot and cold, electric and engine driven - we have what you need

WELDERS

Mig, Arc, Tig and Spot. From DIY to auto/industrial.

METALWORKING

Drills, grinders and saws for DIY and professional use.

WOODWORKING

Saws, sanders, lathes, mortisers and dust extraction.

HYDRAULICS

Cranes, body repair kits, transmission jacks for all types of workshop use.

WATER PUMPS

Submersible, electric and engine driven for DIY, agriculture and industry.

POWER TOOLS

Angle grinders, cordless drill sets, saws and sanders.

STARTERS/CHARGERS

All sizes for car and commercial use.



PARTS & SERVICE: 0208 988 7400

Parts Enquiries
Parts@clarkeinternational.com

Servicing & Technical Enquiries
Service@clarkeinternational.com

SALES: UK 01992 565333 or Export 00 44 (0)1992 565335

Clarke INTERNATIONAL Hemnall Street, Epping, Essex CM16 4LG
www.clarkeinternational.com