

Clarke®



14PC OIL FILTER CAP WRENCH SET

MODEL NO: CHT695

PART NO: 1801695

USER INSTRUCTIONS

LS1211

GUARANTEE

This product is guaranteed against faulty manufacture for a period of 12 months from the date of purchase. Please keep your receipt which will be required as proof of purchase.

This guarantee is invalid if the product is found to have been abused or tampered with in any way, or not used for the purpose for which it was intended.

Faulty goods should be returned to their place of purchase, no product can be returned to us without prior permission.

This guarantee does not effect your statutory rights.

SAFETY



WARNING: THE WARNINGS, CAUTIONS AND INSTRUCTIONS DISCUSSED IN THIS MANUAL CANNOT COVER ALL POSSIBLE CONDITIONS AND SITUATIONS THAT MAY OCCUR. IT MUST BE UNDERSTOOD THAT COMMON SENSE AND CAUTION ARE FACTORS WHICH MUST BE APPLIED BY THE OPERATOR

1. **DO NOT** use tools if damaged. Replace with recommended parts only. Unauthorised parts may be dangerous and will invalidate the warranty.
2. Maintain tools in good and clean condition for best and safest performance.
3. Use in a suitable working area. Keep area clean and tidy, and free from unrelated materials and ensure that there is adequate lighting.
4. Wear approved eye protection. A full range of personal safety equipment is available from your CLARKE dealer.
5. Wear suitable clothing to avoid snagging. **DO NOT** wear jewellery and tie back long hair.
6. Ensure that the floor is not slippery and wear non-slip shoes.
7. Keep children and unauthorised persons away from the work area.
8. **DO NOT** attempt to start the engine whilst there is no oil filter fitted to the vehicle's engine.
9. Ensure all pieces are returned to the case and store this in a safe, dry, childproof location.
10. Dispose of waste oil in accordance with local authority regulations.
11. **If changing the oil filter requires the operator to be underneath the vehicle, always ensure that the vehicle is adequately supported on suitable axel stands and is on a firm level surface and cannot move. The operator must ensure that there is no risk of injury.**

INSTRUCTIONS

Use with 3/8" Sq. drive, or adaptor allows use with 1/2" Sq. drive wrenches.



WARNING: THIS SET IS FOR USE ONLY IN THE REMOVAL OF FILTERS. YOU SHOULD NOT ATTEMPT TO FIT A FILTER USING THIS SET, DUE TO THE RISK OF OVER-TIGHTENING WHICH COULD DAMAGE THE FILTER AND LEAD TO FURTHER COMPLICATIONS. CONSULT THE VEHICLE MANUFACTURER'S SERVICE INSTRUCTIONS FOR SPECIFIC INSTRUCTIONS.

IMPORTANT: These instructions are provided as a guide only. Always refer to the vehicle manufacturer's service instructions, or a proprietary manual, to establish the correct procedure regarding the removal and fitting of an oil filter.

| N0 | Description |
|-----|---|
| 1. | 65 mm - 14 flutes |
| 2. | 68 mm - 14 flutes |
| 3. | 73 mm - 14 flutes |
| 4. | 65/67 mm - 14 flutes |
| 5. | 76 mm - 14 flutes |
| 6. | 75/77 mm - 15 flutes |
| 7. | 76 mm - 30 flutes |
| 8. | 93 mm - 15 flutes |
| 9. | 90 mm - 15 flutes |
| 10. | 100 mm - 15 flutes |
| 11. | 93/36 mm - 36 flutes |
| 12. | 60/62 mm - 15 flutes |
| 13. | 80 mm - 15 flutes |
| 14. | 74/76 mm - 15 flutes |
| 15. | Adaptor 3/8" Male Square Drive - 1/2" Female Square Drive |

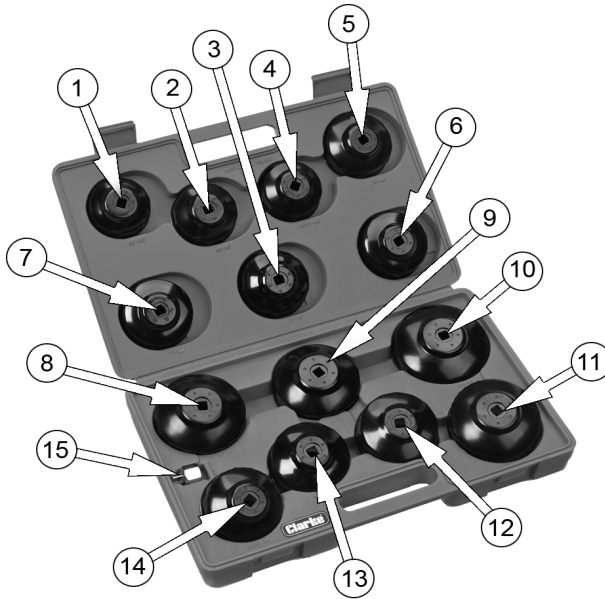

A SELECTION FROM THE VAST RANGE OF

Clarke®

QUALITY PRODUCTS



AIR COMPRESSORS
From DIY to industrial, Plus air tools, spray guns and accessories.

GENERATORS
Prime duty or emergency standby for business, home and leisure.

POWER WASHERS
Hot and cold, electric and engine driven - we have what you need

WELDERS
Mig, Arc, Tig and Spot. From DIY to auto/industrial.

METALWORKING
Drills, grinders and saws for DIY and professional use.

WOODWORKING
Saws, sanders, lathes, mortisers and dust extraction.

HYDRAULICS
Cranes, body repair kits, transmission jacks for all types of workshop use.

WATER PUMPS
Submersible, electric and engine driven for DIY, agriculture and industry.

POWER TOOLS
Angle grinders, cordless drill sets, saws and sanders.

STARTERS/CHARGERS
All sizes for car and commercial use.



PARTS & SERVICE: 020 8988 7400
E-mail: Parts@clarkeinternational.com or Service@clarkeinternational.com
SALES: UK 01992 565333 or Export 00 44 (0)1992 565335

Clarke INTERNATIONAL Hemnall Street, Epping, Essex CM16 4LG
www.clarkeinternational.com