

Clarke® WOODWORKER



600mm COMPOUND MITRE SAW

MODEL NO: MBS600D

Part No: 6461516

ASSEMBLY INSTRUCTIONS

INTRODUCTION

Thank you for purchasing this CLARKE Mitre Saw.

Before attempting to use the product, it is essential that you read this manual thoroughly and carefully follow all instructions given. In doing so you will ensure the safety of yourself and that of others around you, and you can also look forward to the product giving you long and satisfactory service.

GUARANTEE

This CLARKE product is guaranteed against faulty manufacture for a period of 12 months from the date of purchase. Please keep your receipt as proof of purchase.

This guarantee is invalid if the product is found to have been abused or tampered with in any way, or not used for its intended purpose.

Faulty goods should be returned to their place of purchase, no product can be returned to us without prior permission. This guarantee does not effect your statutory rights.

ENVIRONMENTAL PROTECTION

Do not dispose of this product with general household waste. All tools, accessories and packaging should be sorted, taken to a re-cycling centre and disposed of appropriately.

COMPONENT GUIDE

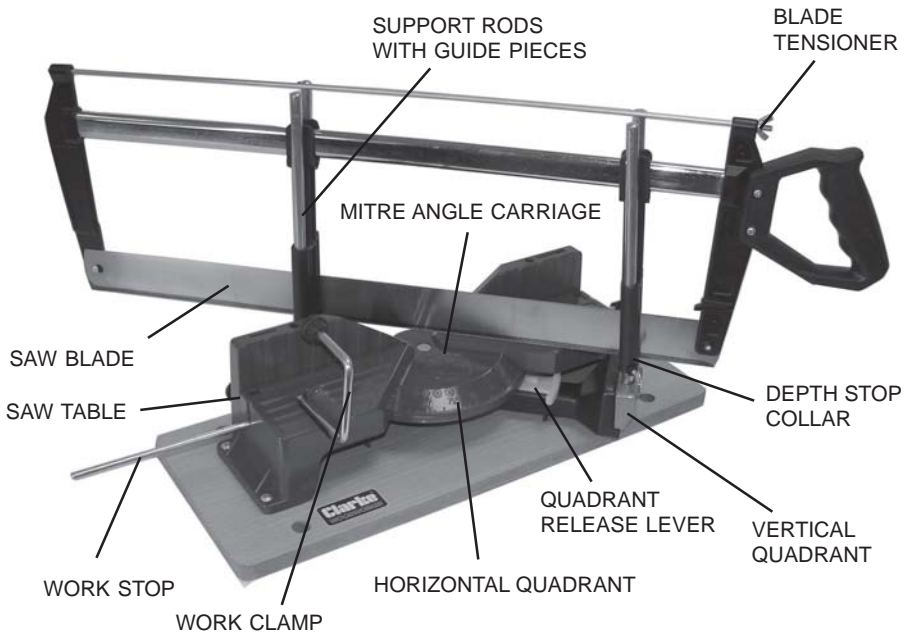

Upon receipt of the product, unpack all loose components and check for any missing parts. Any identified should be reported to your Clarke dealer. The MBS600D includes the following:

- 1 x Saw Table with wooden base
- 1 x 600 mm Saw mounted in Saw Frame
- 4 x Support Rods
- 2 x Polymer Guide Pieces
- 1 x Work Stop
- 1 x Work Retaining Clamp
- 2 x Allen (Hexagonal) Keys
- 2 x Depth Stop Collars
- 1 x Work Clamp Securing Knob
- 1 x Work Stop Securing Knob

ASSEMBLY

GUIDE RODS, SAW FRAME AND BLADE

1. Attach the handle to the upright part of the saw frame using the two screws, with the nuts seated in the handle moulding.
2. Connect the polymer guide pieces to the saw frame assembly as shown in Fig 1.

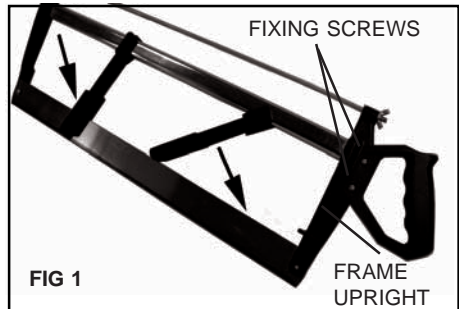

2. Insert the guide support rods through the holes in each guide piece as shown in Fig 2, noting that two of the rods include a small end stop. This must remain at the top of the guide rod.
3. Slide a depth stop collar onto one front and one rear guide rod from below and lock in position with the thumbscrew.

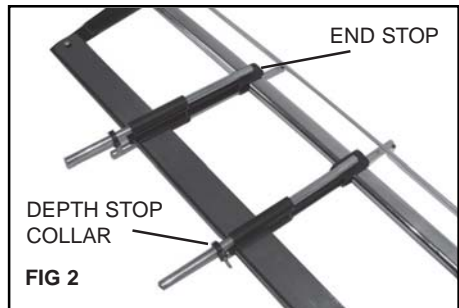

4. Lift the saw frame, complete with guide rods, and place the guide rods into their respective sockets in the mitre angle carriage.
5. Tighten the grub screw for each socket using a hexagonal key to secure the saw frame/guide rod assembly in place.



6. With the saw frame assembly in position, tension the blade using the wing nut, until any sideways deflection of the blade is minimal.
- This is essential to ensure a straight and repeatable cut from the blade.
 - The saw blade can be removed for replacement by loosening the wing nut fully and disengaging the blade from its mounting pegs at each end of the frame.

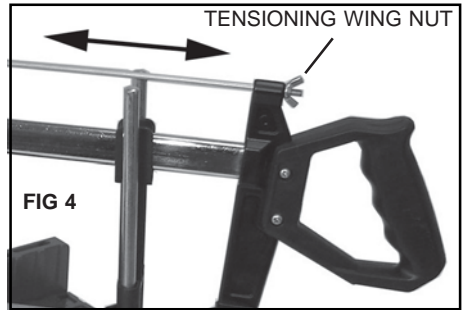

WORK CLAMP

1. Pass the threaded shaft of the work clamp into one of the holes in the front face of the saw table, (see fig 5), depending upon which end of the table your work is to be mounted.
2. Screw on the retaining nut to keep it in place.

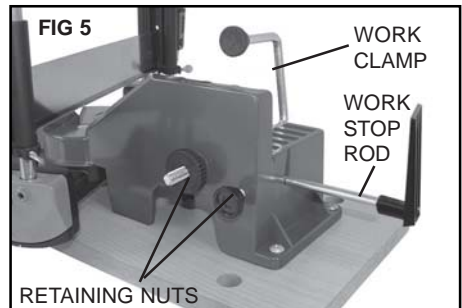

WORK- STOP

1. Screw the stop rod adjusting knob into the threaded hole at one end of the saw table depending upon which side of the saw blade your work is to be mounted.
 2. Slide the work stop rod through the base until it emerges from the hole in the opposite end. Set it in the position required, by tightening the thumb-screw.
- Your saw is now fully assembled and ready for use.

BENCH MOUNTING

You may wish to install the saw on a firm foundation such as a workbench or work table. This is particularly advisable if you are cutting larger workpieces.

Use the holes in the wooden base plate for this purpose, securing with bolts, flat washers and wing nuts for quick and easy removal, if required (not supplied).

USING THE MITRE SAW

CUTTING SIMPLE MITRES OR BEVELS

Simple mitres or bevels are cuts made in one plane only. For simple mitres, the carriage is moved to the desired angle to the base by pulling the horizontal quadrant release lever to allow the carriage to swivel, with the saw blade remaining perpendicular to the table.

Setting the carriage to the angles shown in Fig 6, will produce the mitres illustrated. The angle is shown by the pointer.

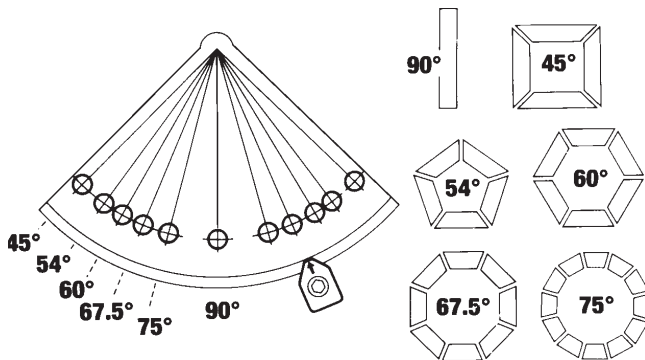
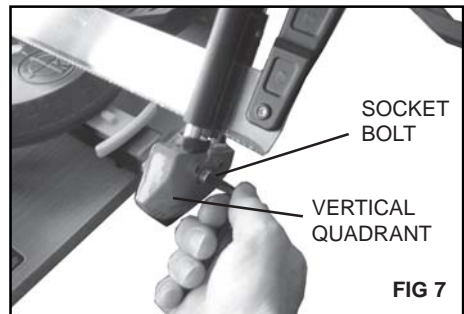

FIG 6

COMPOUND MITRES

For compound mitres the saw frame is tilted over at an angle to the table. This is done by releasing the large socket bolt in each end of the mitre carriage sufficiently to free the vertical quadrant and to allow the saw frame to be tilted to the desired angle. The socket bolt is then tightened when the saw frame is set at the desired angle.



Compound mitres are therefore cut using a combination of these settings.

CUTTING TECHNIQUE

When cutting, DO NOT force the saw blade, as this will lead to blade distortion and inaccurate mitres/bevels. Only a very gentle pressure is required. Let the saw do the work.

Ensure the socket screws at both ends of the carriage are tight before use.

Always clamp the workpiece to the saw table before work.

Ensure the saw blade is correctly tensioned before use - too slack will allow the blade to twist, producing inaccurate mitres. Take care never to use damaged saw blades. Release the blade tension if the saw is not to be used again for some time.

Use the depth stop collars as required when making either a horizontal or sloping cut. Tighten them securely with the thumb-screws before cutting.

Replacement blades are available from your CLARKE dealer;

Part No: 6470175

SPECIFICATIONS

Feature	Specification
Base Width x Length	480 mm x 200 mm
Depth (saw frame)	735 mm
Saw Blade Length	600 mm
Saw Blade Depth	45 mm
Weight	3.8 kg
Max Depth of Cut	150 mm
Max Width of Cut @90°	170 mm
Teeth per Inch	19 tpi

Please note that the details and specifications contained herein, are correct at the time of going to print. However, CLARKE International reserve the right to change specifications at any time without prior notice.

A SELECTION FROM THE VAST RANGE OF

Clarke®

QUALITY PRODUCTS

AIR COMPRESSORS

From DIY to industrial, Plus air tools, spray guns and accessories.

GENERATORS

Prime duty or emergency standby for business, home and leisure.

POWER WASHERS

Hot and cold, electric and engine driven - we have what you need

WELDERS

Mig, Arc, Tig and Spot. From DIY to auto/industrial.

METALWORKING

Drills, grinders and saws for DIY and professional use.

WOODWORKING

Saws, sanders, lathes, mortisers and dust extraction.

HYDRAULICS

Cranes, body repair kits, transmission jacks for all types of workshop use.

WATER PUMPS

Submersible, electric and engine driven for DIY, agriculture and industry.

POWER TOOLS

Angle grinders, cordless drill sets, saws and sanders.

STARTERS/CHARGERS

All sizes for car and commercial use.



PARTS & SERVICE: 020 8988 7400
E-mail: Parts@clarkeinternational.com or Service@clarkeinternational.com

SALES: UK 01992 565333 or Export 00 44 (0)1992 565335

Clarke INTERNATIONAL Hemnall Street, Epping, Essex CM16 4LG
www.clarkeinternational.com