

CLARKE®

STRONG-ARM

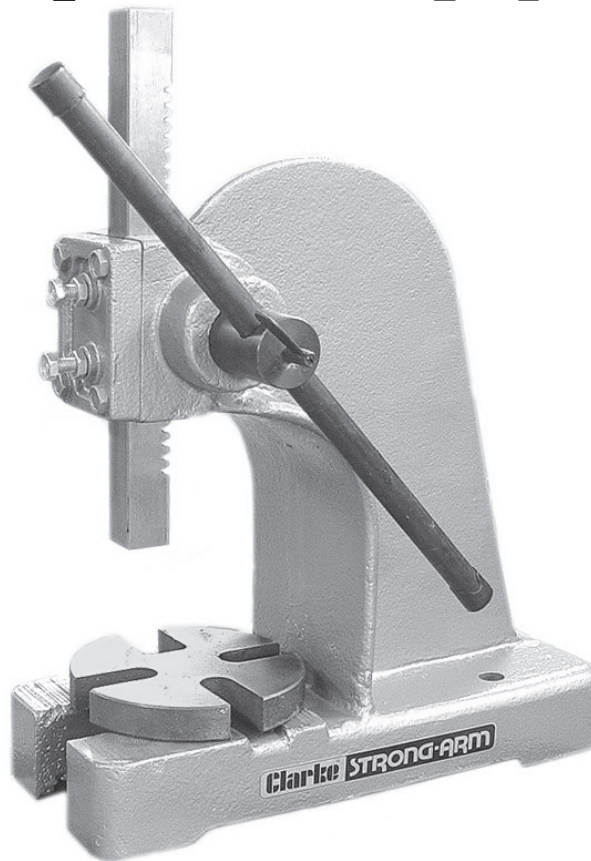

GC 0210

ARBOR PRESS

Model No's: AP500B • AP1000 • AP2000 • AP3000

Thank you for purchasing this CLARKE Arbor Press, which is designed for trade use.

Please read this instruction leaflet thoroughly and follow the instructions carefully. In doing so you will ensure the safety of yourself and that of others around you, this will also ensure that the Arbor Press will give you long and satisfactory service.

Please keep these instructions in a safe place for future reference.

CLARKE GUARANTEE

This CLARKE product is guaranteed against faulty manufacture for a period of 12 months from the date of purchase. Please keep your receipt as proof of purchase.

This guarantee is invalid if the product is found to have been abused or tampered with in any way, or not used for the purpose for which it was intended.

Faulty goods should be returned to their place of purchase, no product can be returned to us without prior permission.

This guarantee does not effect your statutory rights.

Please note that details and specifications herein, are correct at time of going to print.
However CLARKE International reserve the right to change specifications at any time without prior notice.
Copyright CLARKE International All rights Reserved

SAFETY PRECAUTIONS

⚠ WARNING ⚠

As with all machinery, there are certain hazards involved with its operation and use. Exercising respect and caution will considerably lessen the risk of personal injury. However, if normal safety precautions are overlooked or ignored, personal injury to the operator or damage to property, may result.

- **BEFORE** use, secure the press to a suitable work bench.
- **ALWAYS** keep fingers clear of moving parts.
- **ALWAYS** wear safety goggles, manufactured to the latest European Safety Standards. Everyday glasses do not have impact resistant lenses, they are NOT safety glasses.
- **ALWAYS** keep work area clean. Cluttered areas and benches invite accidents.
- **ALWAYS** ensure that adequate lighting is available. A minimum intensity of 300 lux should be provided. Ensure the lighting is positioned where you will not be working in your own shadow.
- **ALWAYS** concentrate on the job at hand, no matter how trivial it may seem. Be aware that accidents are caused by carelessness due to familiarity.
- **ALWAYS** wear proper apparel. Loose clothing or jewellery may get caught in moving parts. Wear protective hair covering to contain long hair.
- **NEVER** operate the machine when under the influence of drugs, alcohol or any medication.
- **NEVER** force the machine, it will do a better and safer job at the rate for which it was designed. Do not attempt to apply more leverage by extending the length of the handle.

TECHNICAL SPECIFICATIONS & PARTS LIST

Model No:	AP500B	AP1000	AP2000	AP3000
Part No:	7615172	7615175	7615180	7615185
General:				
Description:	1/2 Ton Arbor Press	1 Ton Arbor Press	2 Ton Arbor Press	3 Ton Arbor Press
Rated Force:	0.5 Tons	1.0 Tons	2.0 Tons	3.0 Tons
Dimensions & Weights:				
L x W x H	255x120x280mm	270x129x439mm	428x170x662mm	455x271x887mm
Weight:	9.3kg	15.0kg	37.5kg	53.5kg
Detailed Dimensions: (Fig.1 refers)				
'A' Ram Rear to Column:	75mm	90mm	117mm	135
'B' Max. Working Height:	112mm	138mm	206mm	328mm
'C' Throat Depth:	117mm	140mm	198mm	240mm
'D' Ram Size	17mm x 17mm	23.6mm x 23.6mm	31.35mm x 31.35mm	35mm x 35 mm
'E' Working Height:	95mm	118mm	180mm	296mm
'F' Handle Length:	295mm	349mm	462mm	592mm
Parts List:				
Pinion Shaft:	SMAP5001	SMAP1001	SMAP2001	SMAP3001
Ram:	SMAP5002	SMAP1002	SMAP2002	SMAP3002
Table:	SMAP5003	SMAP1003	SMAP2003	SMAP3003

* Rated force dependant on exerted load.

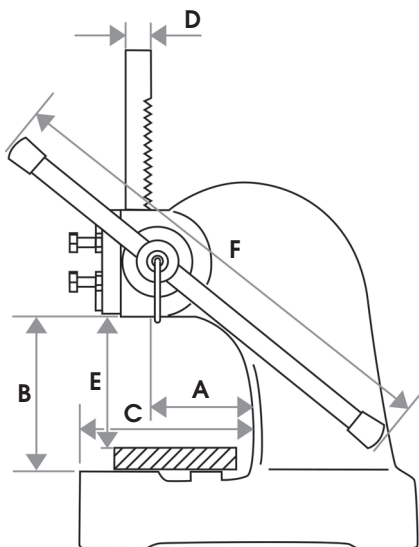

Fig.1

WARNING: The use of spare parts or accessories, other than those supplied by CLARKE international or one of its recognised dealers, may be hazardous and could invalidate the guarantee.

PARTS & SERVICE

Clarke[®]

INTERNATIONAL

For spare parts and servicing, please contact your nearest dealer, or
CLARKE International on:

020 8988 7400

or email:

Parts@clarkeinternational.com

Service@clarkeinternational.com

CLARKE International, Hemnall Street, Epping, Essex, CM16 4LG