

**use &  
maintenance  
MANUAL**

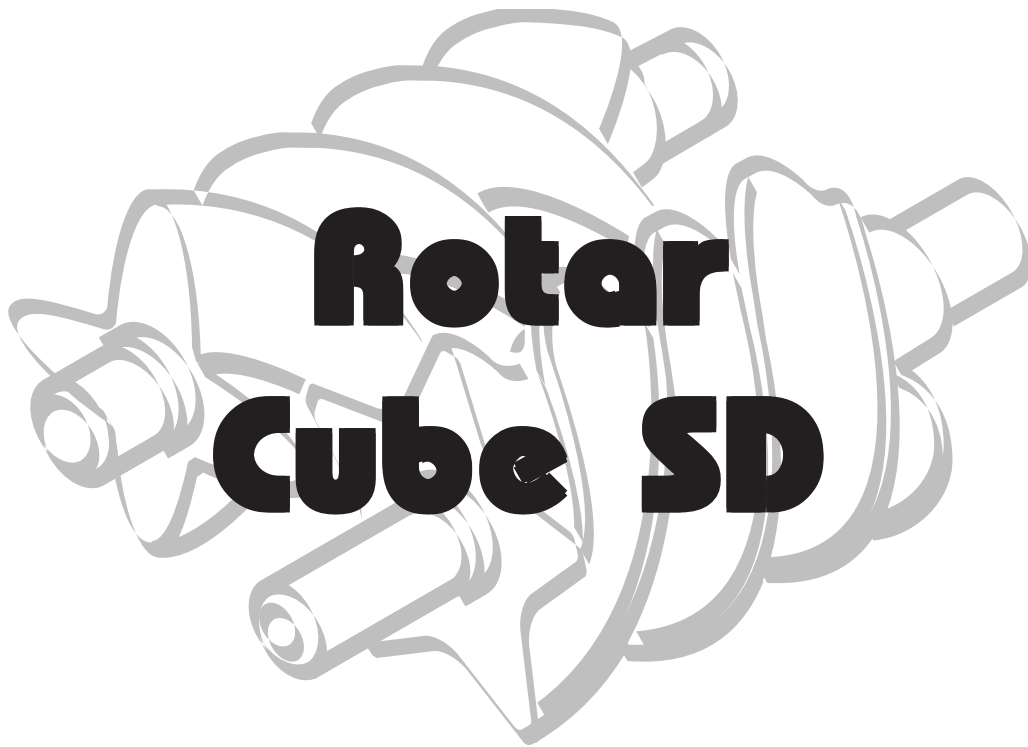

**CE**



GENERAL INFORMATION .....	3
SAFETY INDICATIONS .....	4
INSTALLATION .....	6
TECHNICAL FEATURES .....	7
CONTROLS AND SETTINGS .....	8
ALARMS .....	10
START-UP .....	11
OPERATION .....	12
MAINTENANCE .....	13
TROUBLE SHOOTING .....	16
WIRING DIAGRAM .....	17

## OUTFIT

The following accessories are supplied with the compressor:

- user's guide
- anti-vibration elements
- electric box key
- oil/condensate exhaust tube

Check that the above accessories are available. Once the goods have been delivered and accepted, no complaints are accepted.

## CONDITION OF THE MACHINE WHEN SUPPLIED

Every compressor is shop tested and delivered ready to be installed and to be set at work.

Oil used is: ROTENERGY PLUS.

**GENERAL**

- Rotary compressors are intended for heavy continuous industrial use. They are especially suitable for industrial applications requiring high air consumption for a long time.
- The compressor should be run and operated only in compliance with the indications given in this manual. Safely keep this manual in a known and easily reachable place for the whole working life of the compressor.
- A supervisor shall be appointed in the company, in which the compressor is installed. He/she shall be responsible for compressor inspections, adjustments and maintenance. Should a substitute be appointed for the supervisor, he/she shall carefully read the user's guide and all possible comment on service and maintenance carried out so far.

**SYMBOLS USED IN THE MANUAL**

Some symbols are used to highlight danger situations, give recommendations or information. These symbols are usually positioned next to the text, a figure or at the top of a page (in this case they refer to all subjects dealt with in that page).

Carefully read symbol meaning below.

**CAUTION!**

Important description on service, dangerous situation, safety, accident prevention recommendations and/or very important information.

**POWER OFF!**

All operations to be strictly carried out only after powering off the machine.

**STOP MACHINE!**

All operations to be strictly carried out only after stopping the machine.

**SPECIALIZED PERSONNEL!**

All operations to be strictly carried out only by specialized technician.

**SYMBOLS ON THE COMPRESSOR**

The compressor has several labels to highlight possible danger and give recommendations on what to do during machine operation or in special situations.

Please comply with these indications.



Danger! Hot!



Prohibited! Do not open doors during compressor operation



Danger! Electric shock!



Prohibited! Press emergency button for compressor immediate stop. Do not use line knife switch.



Danger! Hot gas or harmful gas within working area



Prohibited! Do not use water on electric equipment to extinguish fire.



Danger! Pressurized container



Compulsory! Read instructions for use carefully.



Danger! Mechanical moving parts



Caution! Maintenance works in progress



Machine with automatic start-up

## SAFETY INDICATIONS

GB

### WHAT TO DO:

Make sure that mains voltage corresponds to the voltage indicated on CE plate and that cable of suitable cross-section are used for electric connections.

Always check oil level before starting the compressor.

Be familiar with emergency stop control and all other controls.

Unplug the connector before any maintenance work, so to avoid accidental start.

Ensure that all parts have been correctly reassembled after any maintenance work.

Keep children and animals off the working area to avoid injuries caused by devices connected to the compressor.

Ensure that temperature of the working environment ranges between +5 and + 50 °C.

The compressor should be installed and operated in a non-explosive environment.

Allow at least 80 cm between the compressor and the wall so to allow free air flow to the fan.

Press the emergency button on the control panel only in case of actual need so as to avoid possible damages to people or the very compressor.

When calling for technical assistance and/or advice, always mention model and serial number indicated on CE plate.

Always follow the maintenance schedule specified in the user's guide.

### WHAT NOT TO DO:

Do not touch inner parts and pipes as they are very hot during compressor operation and stay hot for a certain time after compressor stops.

Do not position inflammable or nylon objects or cloths close to and onto the compressor.

Do not move the compressor when the tank is under pressure.

Do not operate the compressor if the power cable is damaged or defective or if connection is unstable.

Do not operate the compressor in wet or dusty environments.

Never aim the air jet at people or animals.

Do not allow unauthorized people to operate the compressor and give them all required instructions.

Do not hit fans with blunt objects as they might break during compressor operation.

Never operate the compressor without air filter.

Do not tamper with safety and adjusting devices.

Never operate the compressor when doors/panels are open or removed.

### PRODUCT IDENTIFICATION

The compressor You have purchased has its own CE plate showing the following data:

- 1) Manufacturer's data
- 2) CE mark – year of manufacture
- 3) TYPE = name of the compressor  
CODE = compressor code  
SERIAL NO. = serial number of the compressor You have purchased (to be always mentioned when calling for technical assistance)
- 4) air delivered by the compressor expressed in (l/min) and (cfm)
- 5) max. operating pressure (bar and PSI) – compressor noise level in dB(A)
- 6) electric data: voltage (V/ph), frequency (Hz), absorption (A) - power (HP and kW), rotations per minute (Rpm).
- 7) other approvals

1	CE 2
3	
4	5
6	7

Read this page carefully before performing any operation on the compressor

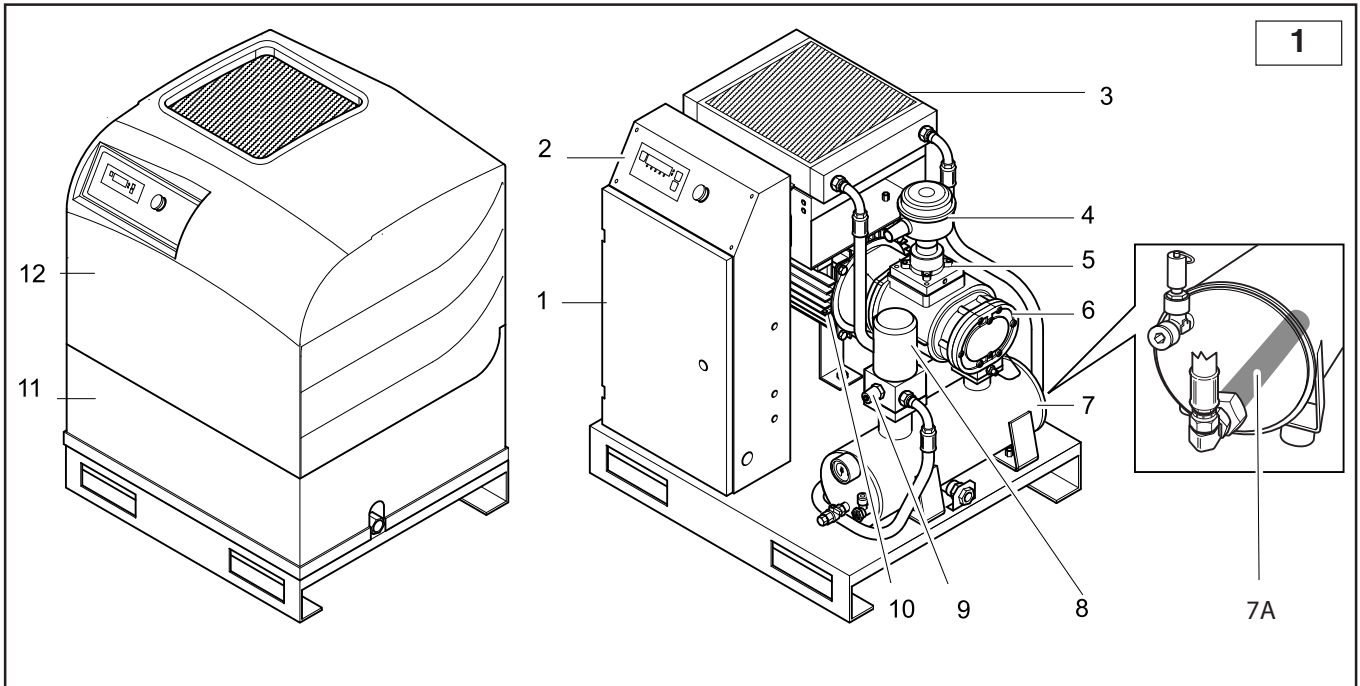

### MACHINE DESCRIPTION (fig.1)

The compressor essentially consists of the following:

- |                         |                           |
|-------------------------|---------------------------|
| 1. Electrical equipment | 7A. Oil filter            |
| 2. Control panel        | 8. Oil separator filter   |
| 3. Oil radiator         | 9. Minimum pressure valve |
| 4. Air filter           | 10. Electric motor        |
| 5. Suction regulator    | 11. Lower fairing         |
| 6. Screw compressor     | 12. Upper fairing         |
| 7. Oil separator tank   |                           |

### UNPACKING AND HANDLING THE MACHINE

When delivered, compressor top is protected by cardboard packing.

Wear suitable protective gloves and then cut outer straps and then remove cardboard from the top. Check the (outer) good condition of the machine before moving the compressor. Visually check that no parts are damaged. Also ensure that all accessories are available.

Lift the machine using a fork lift truck. Fit the anti-vibration elements into their proper seat and move the machine to the room chosen for its location with maximum care.

Keep all packing materials at least for the warranty period for possible moving. In case of need, it will be safer for delivery to the technical assistance dept.

**Then, dispose of packing materials in compliance with current laws.**

### LOCATION (fig. 2)

The room chosen for the installation of the compressor should meet the following requirements and comply with what is specified in the current safety and accident prevention regulations:

- **low percentage** of fine dust,
- **proper room ventilation and size** that allow room temperature under 50°C. In the event of inadequate hot air discharge, fit the exhaust fans as high as possible.

Exhaust flow rate "2000 m<sup>3</sup>/hr" part no. 020041000

Exhaust flow rate "4000 m<sup>3</sup>/hr" part no. 020042000

Condensate should be collected either into a pit or a tank.

The dimensions of the spaces are indicative only but it is advisable to follow them as closely as possible.

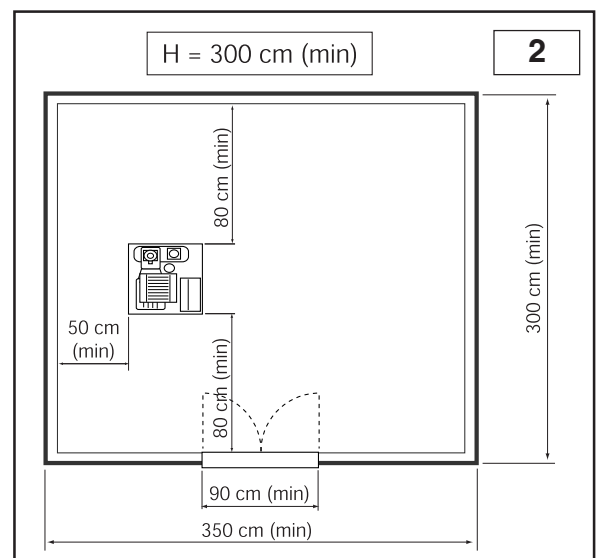

# INSTALLATION

## ELECTRICAL HOOK-UP (fig. 3)

- The mains cable should have a cross-section suitable for the machine power and should include **no. 3** phase wires, no. 1 neutral cable and **no. 1** earth wire.
- Between the mains cable and the compressor control panel a fused switch near the point where the cables go into the machine is **absolutely necessary**. The switch should be at least at 1.7 m from the ground.
- The switch (A) should be easily reached by the operator. The cables should be of the approved type and installed with the following grade of protection: minimum IP44

**N.B.** Follow the instructions in the table to select proper cable section.

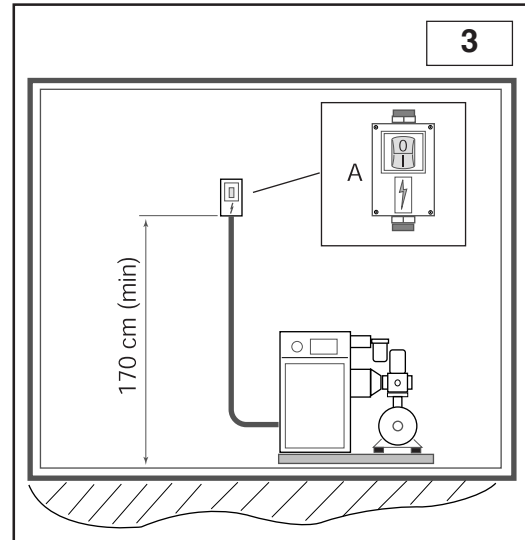

## TECHNICAL FEATURES

Technical features		Cube SD5 (Direct start)	Cube SD5	Cube SD7	Cube SD10
Pressure	bar	10	10	10	10
Compressor type	type	FS26TFC	FS26TFC	FS26TFM	FS26TFC
Compressor rotation speed	rpm	1400	1400	2900	2900
Air volume supplied	l/min	460	460	705	1050
Oil quantity	l	3,5	3,5	3,5	3,5
Oil quantity for topping-up	l	0,5	0,5	0,5	0,5
Max. final over temperature	°C	20	20	20	20
Removed heat	kJ/h	13680	13680	18800	25600
Fan flow rate	m <sup>3</sup> /h	670	670	670	1060
Oil residues in the air	mg/m <sup>3</sup>	4	4	4	4
Electric motor	type	112 MC/4	112 MC/4	112 MC/2	112 MC/2
Motor power	kW	4	4	5,5	7,5
Max. power absorbed	kW	4,7	4,7	7,1	8,6
Electrical box protection class	IP	54	54	54	54
Max. Start-up per hour	n°	10	10	10	10
Ambient limit temperature	°C	+2/+45	+2/+45	+2/+45	+2/+45
Noise level	dB(A)	63	63	68	67
<b>Electrical data</b>					
Voltage	V/Hz	400/50-60	400/50-60	400/50-60	400/50-60
Auxiliary voltage	V/Hz	24/50-60	24/50-60	24/50-60	24/50-60
Start-up Absorbed current	Amp	52	24	30	34
Max. Absorbed current	Amp	9,8	9,8	11,8	14,6
Max. Absorbed current (vacuum)	kW	1,82	1,82	2,74	3,16
Electrical motor protection class	IP	55	55	55	55
Motor insulation class		F	F	F	H
Service factor		1,1	1,1	1,1	1,1
<b>Protection devices</b>					
Max oil temperature	°C	110	110	110	110
Pre-alarm Oil temperature	°C	105	105	105	105
Motor thermal relay setting	Amp	10,5	6,4	6,8	10,5
Safety valve setting	bar	14	14	14	14
<b>Dimensions and weight</b>					
Length	mm	570	570	570	570
Width	mm	630	630	630	630
Height	mm	800	800	800	800
Weight	kg	96	96	96	96
Air fitting	Rp	½"	½"	½"	½"

**CONTROL PANEL**

• All compressor power-on-and-off procedures are controlled by the machine power unit. Furthermore, it signals possible machine problems and gives information on the operation times and the maintenance operation times

**Figure 4:**

1. START key:  
controls start up of the compressor.
2. RESET key:  
controls turning off of the compressor.
3. "Function" key:  
allows movement from one display to the other.
4. Display:  
shows the information.
5. Alarm warning lights:  
turn on in case of alarm.
6. Screw warning light:  
turning on means that the compressor is loading.
7. Stand-by warning light:  
turning on indicates the compressor is waiting.
8. Emergency shutdown button:  
pressing this button causes immediate stoppage of the compressor. **To be used only and exclusively** in the event of real need.

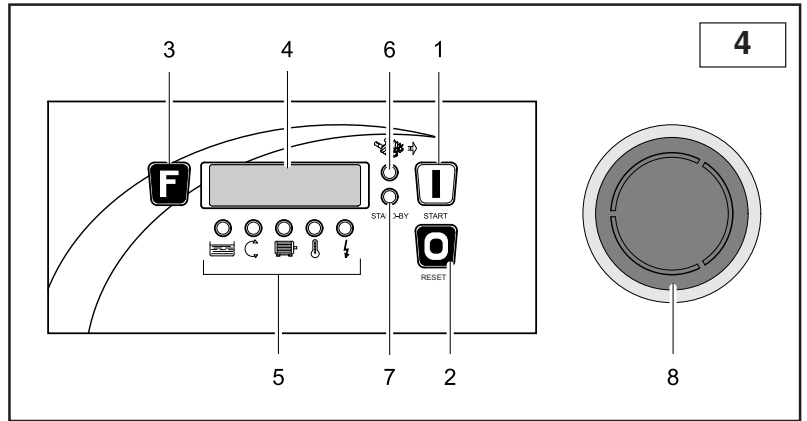
**WORKING TIMES****Automatic mode**

- The compressor operation is controlled by the pressure switch, which stops the machine when the max. pressure value is reached and starts it again after the pressure has decreased to the min. set value.
- Stoppage of the compressor is delayed; by pressing RESET (2) the compressor begins to operate loadless and stops after 60 seconds. The Standard setting is 60 seconds, but it is recommended to check that number of start-ups per hour does NOT exceed max number of 10. Should it be a higher value, it is recommended to set longer loadless operation time and avoid useless turning on and off cycles.

**PRESSURE REGULATOR**

The User should install a pressure regulator downstream of the compressor to set the power line according to his/her needs.



## MODIFIABLE PARAMETERS

These settings apply exclusively to the models fitted with Easytronic II Micro power unit.

### User menu

With the compressor off, keep the "Function" key pressed for at least 5 seconds.

N°	Parameter	U.M	Min. value	Default value	Max value
U0	Set loadless pressure (*)	Bar	0.5	10.0	15.0
U1	Set loading pressure (**)	Bar	0	8.5	(Set P loadless) – 0.5
U2	Unit of measure (***)	Bar/Psi	0	1	1

- to select the parameter desired use START (forward) and RESET (back) keys,
- then press the FUNCTION key to show the value of the chosen parameter,
- to change the value use START (to increase) and RESET keys (to decrease),
- confirm the value set by pressing the FUNCTION key.
- The power unit returns to the main menu, and after 5 seconds without pressing any key it returns to the standard display.

(\*) Set loadless pressure: indicates the value of pressure at which the compressor starts the loadless operating cycle.

(\*\*) Set loading pressure: indicates the value of pressure at which the compressor starts compressing air again.

(\*\*\*) 1=bar, 0=psi

### Assistance menu

The settings below must be performed only by authorised technicians.

With the compressor off or in alarm status, keep the "FUNCTION" and "RESET" buttons pressed for at least 5 seconds, then a password will be requested.

N°	Parameter	U.M	Min. value	Default value	Max value
A0	Temperature to power fan	°C	0	80	150
A1	Time loadless	sec.	30	75	900
A2	Delay time in stoppage phase	sec	30	60	900
A3	Enable pressure sensor (*)		0	1	1
A4	Enable temperature sensor (*)		0	1	1
A5	Enable automatic start (*)		0	0	1
A6	Enable phase sequence (*)		0	1	1
A7	Expiry oil hours	hours	0	2000	65536
A8	Expiry oil filter hours	hours	0	2000	65536
A9	Expiry air filter hours	hours	0	2000	65536
A10	Expiry oil separator hours	hours	0	4000	65536
A11	Total hours (**)	hours	0	—	65536
A12	Loading hours (**)	hours	0	—	65536
A13	Reset parameters (***)		0	0	2

(\*) 1=enabled, 0=disabled

(\*\*) it is the real value of use of the compressor

(\*\*\*) adapts the default parameters to the models of compressors on which the power unit is installed

- to select the parameter desired use START(forward) and RESET keys (back),
- then press the FUNCTION key to show the value of the chosen parameter,
- to change the value use START (to increase) and RESET keys ( to decrease),
- confirm the value set by pressing the FUNCTION key.
- The power unit returns to the main menu, and after 5 seconds without pressing any key it returns to the standard display.

During normal operation of the compressor the following signals can occur:

Alarm warning lights (rif.5, fig.5)



Water in the oil separator tank.

Blinking warning light = signal without compressor block

Fixed warning light = compressor block

Drain the condensate from the oil separator tanks (see chapter "Maintenance").



The warning light turns on to indicate a wrong electrical connection. The compressor blocks.

Check connection to the mains cable and to the terminals of the electrical panel of the compressor.

Oil temperature.

Blinking warning light = pre-alarm without compressor block

Fixed warning light = alarm with compressor block

Let the compressor cool down and check the oil level.



The maximum temperature of the motor has been exceeded. The compressor blocks.

Let the motor cool down and check setting of thermal relay.



Indicates there has been a blackout. The compressor blocks.

With compressor stopped, press RESET to disable the alarm before restarting.



Alarm messages, the following alarms are shown on screen:

- |     |  |
|-----|--|
| AL1 | Faulty or broken temperature sensor with blockage of compressor.<br>Replace sensor.  |
| AL2 | Faulty or broken pressure sensor with blockage of compressor.<br>Replace sensor.   |
| AL3 | No phase or phase sequence transformer not operational with blockage of compressor.<br>Check presence of phase and if necessary replace transformer. |
| AL4 | Maximum alarm pressure with blockage of compressor.<br>Contact an assistance centre to remove the cause of the problem.                              |
| AL5 | Fast rise in temperature with blockage of compressor.<br>Contact an assistance centre to remove the cause of the problem.                            |
| AL6 | The emergency button has been pressed.<br>Reset the button to correct position.  |

All alarms cause the compressor to block, which can be restarted only when the problem which has caused the blockage is resolved.

The alarm signal remains even after the problem has been solved, to disable it press the RESET button before restarting the compressor.

Maintenance signalling

The power unit also signals periodic maintenance operations, the internal counters decrease at each hour of loading of the compressor until zero is reached, at this point the maintenance signal will appear on the display:

- |     |  |
|-----|--|
| CH1 | Expiry of oil hours.<br>Replace oil.                           |
| CH2 | Expiry of oil filter hours.<br>Replace oil filter              |
| CH3 | Expiry air filter hours<br>Replace air filter.                 |
| CH4 | Expiry of oil separator hours<br>Replace oil separator filter. |

If more signals are verified at the same time they are displayed in sequence.

Once the maintenance has been performed the internal counters must be reprogrammed.

Before starting the machine for the first time, **check that:**

- the mains voltage is the same as the voltage on the CE plate;
- the electric connections have been made using cables of proper cross-section,
- the (wall) main power switch has suitable fuses;
- the oil level is over the minimum level - top up with the same type of oil if necessary;

**CONNECT THE TANK WITH A HOSE.**

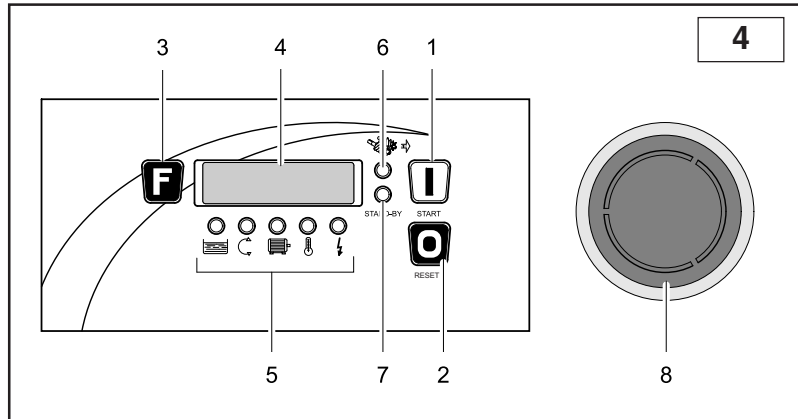

**Only specialised technicians can start the compressor for the first time.**

The **turning on procedure** starts by pressing the START key (1).

The stand-by led (7) blinks and after a few seconds the presence of the phases and their correct sequence is checked, if the compressor blocks and the warning light turns on the phase sequence device has intervened, press the RESET key (2) and bring the wall switch to OFF position. Open the electric compartment and invert the position of two phases in the power terminal box. Close the electrical compartment and restart.

The start up procedure is repeated: the Screw led (6) blinks and after a few seconds it becomes fixed, the load phase starts until the “set loadless pressure” value is reached.

The Screw led (6) blinks again and the loadless operation phase begins.

If at the end of the loadless operation (default 75 sec.) the pressure has not fallen below the “set load pressure” value the compressor stops and the stand-by led turns on (7); otherwise upon reaching the “set load pressure” value the compressor restarts the loading phase and the Screw led turns on in fixed mode (6).

During routine operation the following information is displayed on screen:

- pressure,
- temperature,
- total hours of operation (with compressor on),
- hours of operation loaded (with compressor in load phase).

By pressing the RESET key (2) the **turn off procedure** starts, the Screw led (6) blinks and the compressor enters the loadless operation mode for the time set by the parameter “delayed stop time” (default 60 sec.). At the end of the cycle the compressor stops.

**SAFETY AND CONTROL DEVICES (fig.5)**

- 1) Pressure switch : regulates STOP and START pressure
- 2) Safety valve: opens the air drainage to the safety valve.
- 3) Minimum pressure valve: prevents leakage of compressed air if the pressure is below the calibration value of the valve
- 4) Maximum temperature probe: shuts down motor when 110° is exceeded

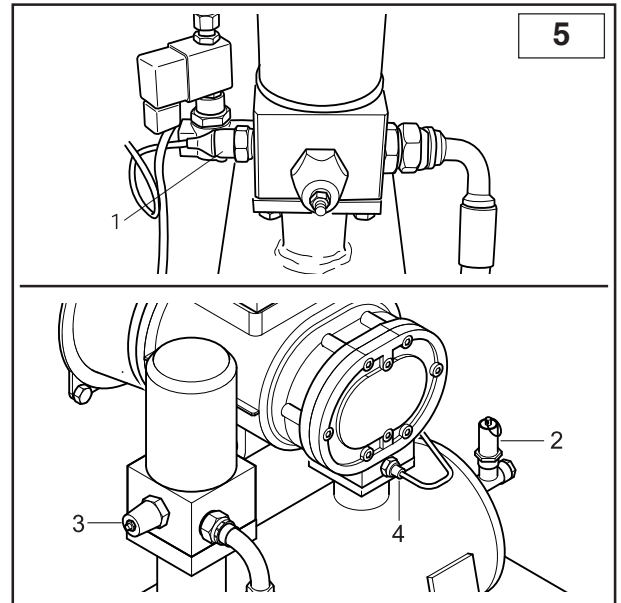
**OPERATING CYCLE**Cube 5 Direct starting

- 1) in the first start up the motor starts directly; it reaches standard speed after 5-7 seconds.

Cube 5- 7-10 Remote starting

- 1) At first start up the motor starts in the "star" configuration. In this phase the compressor starts slowly, the solenoid (1) is open, and the suction regulator (2) is closed.

The compressor remains in this condition for about 5÷7 seconds, after this time the motor is powered by the "delta" configured circuit.

- 2) The solenoid valve (1) receives current and closes allowing the opening of the suction regulator (2), which intakes atmospheric air through the filter (3).

- 3) At this stage, the compressor runs at full speed and begins to compress the air in the tank (6).

- 4) The compressed air cannot come out from the minimum pressure valve set at 3÷4 bar.

- 5) The compressed air compresses the oil in the tank (6) and forces it to flow through the filter (8) and pipe (7) to the radiator (9).

- 6) If the oil temperature is below 80 °C the solenoid valve stays still.

- 7) If the oil temperature exceeds 80°C the solenoid valve starts operating and cooled oil returns to the compressor through tubes (5).

- 8) The oil reaches the compressor (4) mixing with the intake air creating an air/oil mixture which ensures the seal and the lubrication of the moving parts of the compressor.

- 9) The air/oil mixture returns to the tank (6) where the air is pre-separated and later a final separation of the oil takes place, through the oil separator filter (10), and finally it is conveyed to the distribution network.

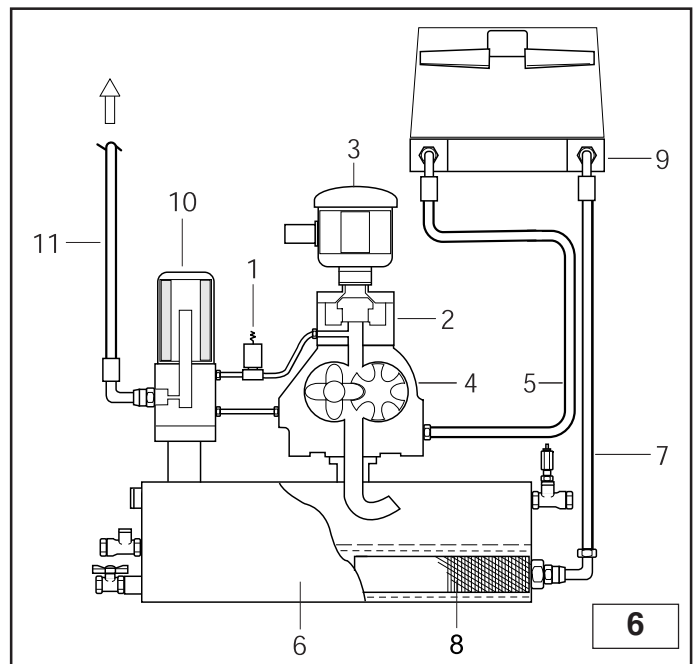

- Correct maintenance is crucial to achieve maximum efficiency of your compressor, and to lengthen its operating life.
- It is also important to comply with the maintenance intervals recommended, but it must be remembered that such intervals are suggested by the manufacturer in the event that the environmental conditions of use of the compressor are optimal (see "Installation" chapter).
- The maintenance intervals can therefore be reduced depending on the environmental conditions in which the compressor operates.
- The oil used is RotEnergy Plus, the use of a different oil does not guarantee perfect efficiency and compliance with the maintenance intervals.
- The following pages describe the routine maintenance operations which can be performed by the person in charge of the compressor, the non-routine maintenance operations must instead be performed by an authorised technical assistance centre.

## Maintenance table

MAINTENANCE OPERATION	MAINTENANCE INTERVAL	
	working hours	at least
<i>ROUTINE MAINTENANCE</i>		
Condensate drain	-	1 time a month
Check oil and possible top up	500	-
Clean air filter	1000	-
Check blockage and clean radiator	1000	- -
<b>Replace air filter</b>	<b>2000</b>	<b>1 time a year</b>
<b>Replace oil filter</b>	<b>2000</b>	<b>1 time a year</b>
<b>Replace oil separator filter</b>	<b>4000</b>	<b>1 time a year</b>
<b>Replace oil</b>	<b>2000</b>	<b>1 time a year</b>
<i>NON-ROUTINE MAINTENANCE</i>		
<b>Replace one-way drain valve</b>	<b>4000</b>	<b>1 time a year</b>
Review suction valve	12000	-
Review thermostat valve	12000	-
Review minimum pressure valve	12000	-
Replace solenoid valve	12000	-
Replace bearings electric motor	12000	-
Replace hoses	12000	- -
Review screw	24000	-

If the hourly limit is not reached, the maintenance operations highlighted in **bold** must be performed at least **1 time a year**.

- To verify correct machine operation, perform the following checks **after the first 100 hours of work**:

- 1) **Check the oil level**: top up with the same type of oil if necessary.
- 2) **Check for proper screw tightening**: in particular the power electric connection screws.
- 3) Visually check that all **fittings seal properly**.
- 4) Check **room temperature**.

### BEFORE MAINTAINING THE MACHINE ALWAYS PERFORM THE FOLLOWING:

- √ Press the machine automatic stop button (do not use the emergency button).
- √ Power the machine off by means of the wall outer switch.
- √ Close the line cock.
- √ Make sure that no compressed air is inside the oil separator tank.
- √ Remove fairing and/ or panels.

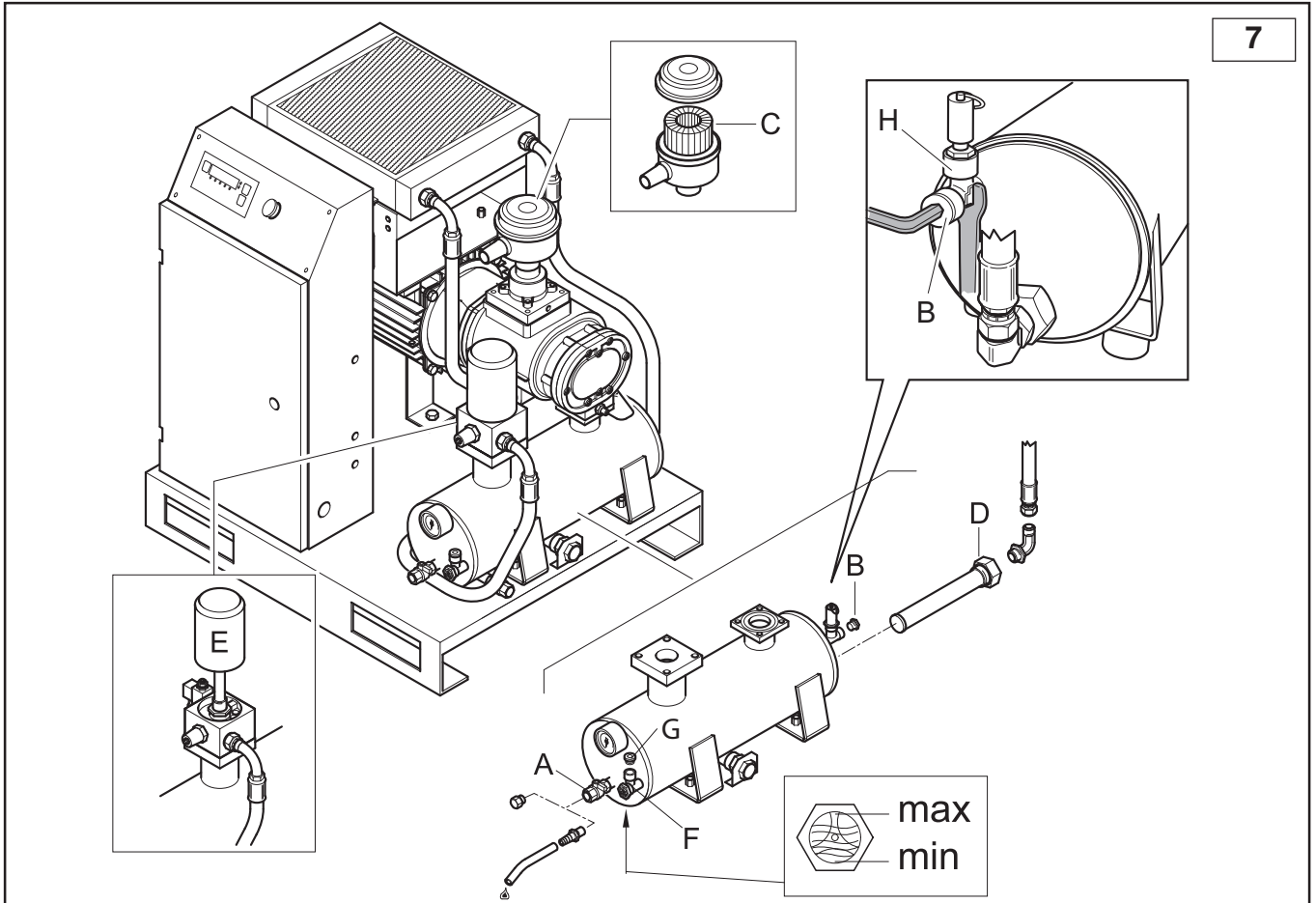

### DRAIN CONDENSATE

The oil/air mixture cooling is set at a higher temperature with respect to the dew point of the air (under standard operating conditions of the compressor). However, the condensate in the oil cannot be fully removed.

Blow off compressed air through cock **A** and then close it as soon as oil begins to flow out instead of water. Check the oil level and top up if necessary

**CONDENSATE IS A POLLUTING MIXTURE!** It must not be let into the sewage.

### OIL CHECK AND TOP UP IF NECESSARY

Check oil level through the warning light on the left side of the oil separator tank, if the level is below the maximum, top up through union **F**; before topping up keep fitting **H** in a vertical position with a key and unscrew plug **B** to allow the air to exit during the top up.

The quantity of oil required to top up from the minimum to the maximum level is about 0.5 litres.

### CLEAN / REPLACE AIR FILTER

Clean the air filter **C** from the inside towards the outside using compressed air.

Check against the light for possible cuts: replace the filter if any.

The filter cartridge and the cover should be assembled with care, so that no dust goes into the compression unit.

### CLEAN RADIATOR

Clean the radiator in case of excessive over temperature and at least once a year.

Proceed as follows:

- Remove the radiator unit and spray (with spray gun + solvent) from the outside towards the inside;
- check for proper air flow through the radiator.

### CHANGE OIL

When the compressor temperature is over 70°C change the oil.

- Insert the hose supplied onto cock **A**.
- Keep the fitting **H** in a vertical position with a spanner and unscrew the plug **B** to allow the air to flow out
- Open cock **A** and allow oil to flow into a collection tray, until complete drainage. Close the cock and remove the hose.
- Remove plug **G** and pour new oil from union **F** (quantity to fill up completely: 3.5 litres).
- Close plug **B** and plug **G**.
- Power the machine on.

## MAINTENANCE

- Start the machine and wait 5 minutes, then stop the machine.
- Blow the air off.
- Wait 5 minutes and check the oil level; top up if necessary.

**The oil used is: RotEnergy Plus**

**THE EXHAUSTED OIL IS HIGHLY POLLUTANT!** For its disposal comply with the current laws on environmental protection.

### CHANGE OIL FILTER

Change oil filter **D**: this must occur when the tank is not under pressure and without oil.  
Always apply some oil on the O ring seal of the filter, before refitting it manually.

### CHANGE OIL SEPARATOR FILTER

The oil separator filter **E** cannot be cleaned, but must be replaced.

- Unscrew filter manually (or if necessary use an appropriate filter tool) turning it anticlockwise.
- After having slightly greased the oil separator filter seal and O-ring, fit the new filter by turning clockwise.



**TROUBLESHOOTING**

<b>Problem</b>	<b>Cause</b>	<b>Remedy</b>
Motor stopped (thermal relay operation signal)	Voltage too low	Check voltage, press Reset and then restart.
	Overtemperature	Check motor absorption and relay setting. In case of regular absorption press Reset and restart.
	Fan motor overtemperature	Check fan motor and clixon condition
Oil consumption high	Drainage faulty	Check oil drain hose and check valve
	Oil level too high	Check oil level and drain some, if necessary
	Oil separator filter broken	Replace oil separator filter
	Oil separator filter seal leaking	Replace oil separator nipple seals
Intake filter leaks oil	Intake regulator stays open	Check regulator and solenoid valve
Safety valve opening	Pressure too high	Check service pressure switch setting
	Intake regulator does not close at the end of the cycle	Check regulator and solenoid valve
	Oil separator filter clogged	Replace oil separator filter
Sensor for compressor temperature triggered	Room temperature too high	Improve ventilation
	Radiator clogged	Clean radiator with solvent
	Oil level too low	Top up oil
	Cooling fan does not start	Check fan motor and clixon condition
Compressor performance low	Air filter dirty or clogged	Clean or replace filter
Compressor does not compress air while running	Regulator closed. It cannot open because dirty.	Remove intake filter and check for proper manual opening. Remove and clean, if necessary.
	Regulator closed. It cannot open because no command is received.	Check for signal on solenoid valve. Replace damaged part, if any.
Compressor compresses air over max. pressure value	Regulator open. It cannot open because dirty.	Remove and clean regulator
	Regulator open. It cannot open because no command is received.	Check for signal availability between pressure switch and solenoid valve. Replace damaged part, if any.
Compressor does not start	Oil separator filter clogged	Replace oil separator filter
	Min. pressure valve does not close perfectly	Remove the valve, clean and replace seal, if necessary
Compressor hardly starts	Voltage too low	Check mains voltage
	Tube leaking	Tighten fittings



# WIRING DIAGRAM - ROTAR CUBE 5 230-400V / 50-60Hz

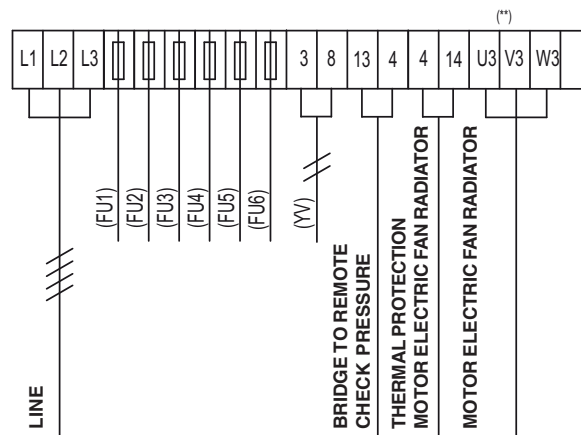
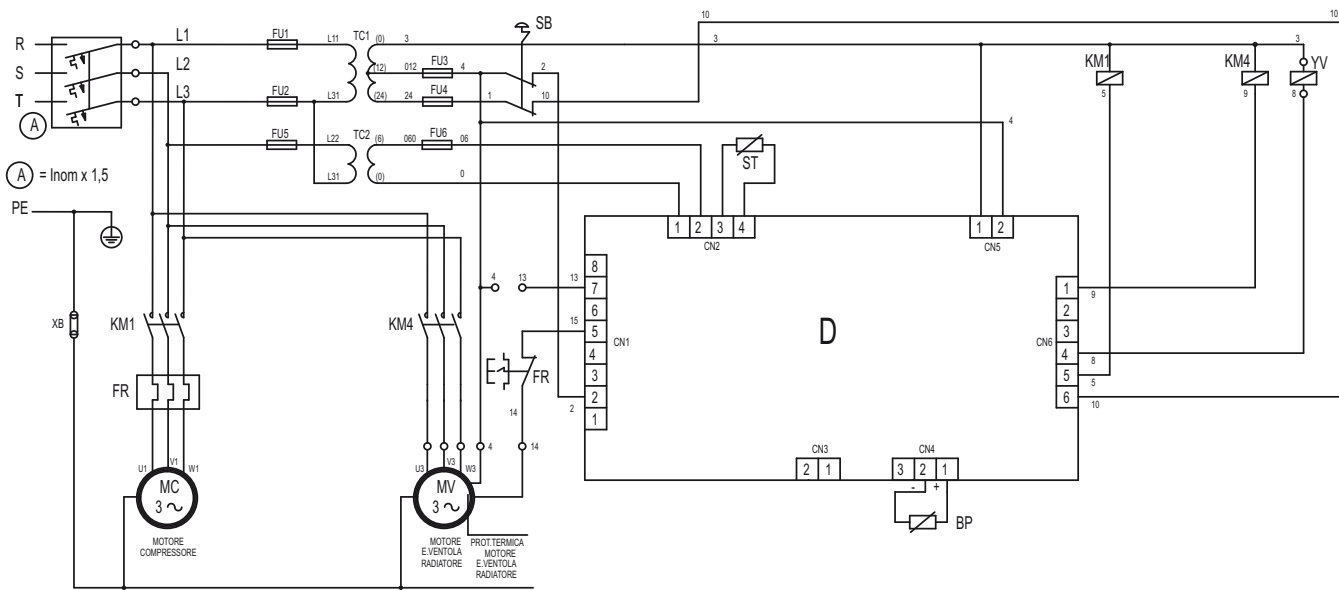

230V      400V      (\*) = 400V AC3

TC1	Transformer 63VA Pr.0/230/400 Sec.0/12/24		
TC2	Transformer Pr.0/230/400 Sec.0/6		
SB	Emergency button + 2NC 230V 10A		
FU1/FU2/FU4	Ceramic fuses 6.3x32 GF 4A 500V		
FU3 / FU5	Ceramic fuses 6.3x32 GF 1A 500V		
FU6	Ceramic fuses 6.3x32 GF 500mA 500V		
KM1	Contactore mot. compressore bobbin24V/50-60Hz	11 kW(*)	5.5 kW(*)
KM4	Contactore fan radiator bobbin24V/50-60Hz	3 kW(*)	3 kW(*)
FR	Thermal relay / Reset man/aut - 1L+1R	(14-20)	(9-12)
YV	Solenoid valve 24 VAC 50/60 Hz 8VA		
BP	Pressure switch 0.-16 bar 4-20 mA		
D	Easytronic electronic controller II 24V/AC		
ST	Thermal probe		
MV	Motor electric fan radiator 230/400V 50/60Hz	68/W	68/W
	Sec. Cable motor (mm²)	4G4	4G1.5

**WIRING DIAGRAM - ROTAR CUBE 5-7-10 TA - 230-400V / 50-60Hz**

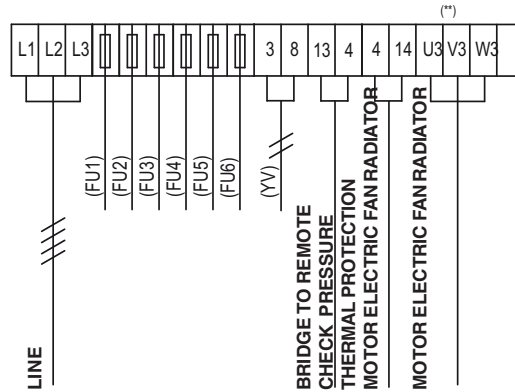
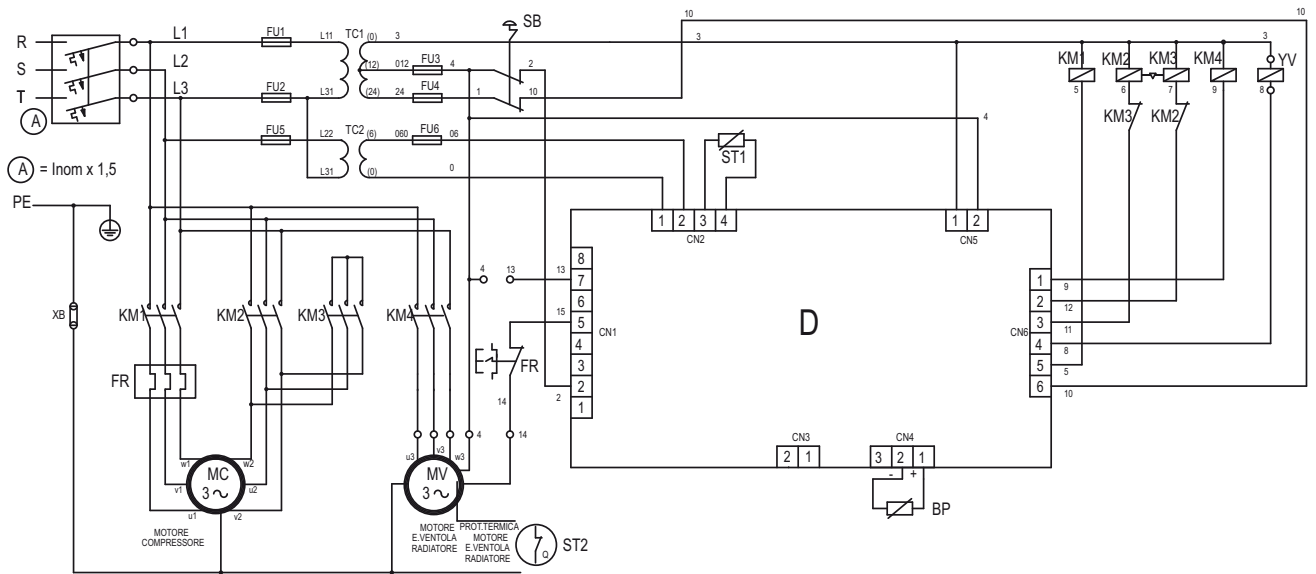

	Cube 5		Cube 7		Cube 10	
	230V	400V	230V	400V	230V	400V

TC1	Transformer Pr.0/230/400 Sec.0/12/						
TC2	Transformer Pr.0/230/400 Sec.0/6						
SB	Emergency button + 2NC 230V 10A						
FU1/FU2/FU4	Ceramic fuses 6.3x32 GF 4A 500V						
FU3/FU5	Ceramic fuses 6.3x32 GF 1A 500V						
FU6	Ceramic fuses 6.3x32 GF 500mA 500V						
KM1	Contactor line bobbin 24V/50-60Hz	5.5kW(*)	4kW(*)	7.5kW(*)	4kW(*)	11kW(*)	5,5kW(*)
KM2	Contactor triangle bobbin 24V/50-60Hz	5.5kW(*)	4kW(*)	7.5kW(*)	4kW(*)	11kW(*)	5,5kW(*)
KM3	Contactor star bobbin 24V/50-60Hz	4kW(*)	4kW(*)	5.5kW(*)	4kW(*)	7.5kW(*)	4kW(*)
KM4	Contactor fan radiator bobbin 24V/50-60Hz	3kW(*)	3kW(*)	3kW(*)	3kW(*)	3kW(*)	3kW(*)
FR	Thermal relay / Reset man/aut - 1L+1R	(9-12)	(5.5-8)	(9-12.5)	(7-10)	(14-20)	(3-12)
YV	Solenoid valve 24 VAC 50/60 Hz 8VA						
BP	Pressure switch 0.-16 bar 4-20 mA						
D	Easytronic electronic controller II 24V/AC						
ST1	Thermal probe for controller						
MV	Motor electric fan radiator 230/400V 50/60Hz						
	Sec. cable motor (mm <sup>2</sup> )	7G1.5	7G1.5	7G2.5	7G1.5	7x4	7G2.5

(\*) = 400V AC3